

INDOOR AIR QUALITY

ENERGY RECOVERY

# OEM WHEEL EQUIPMENT

## ENTHALPY RECOVERY WHEELS

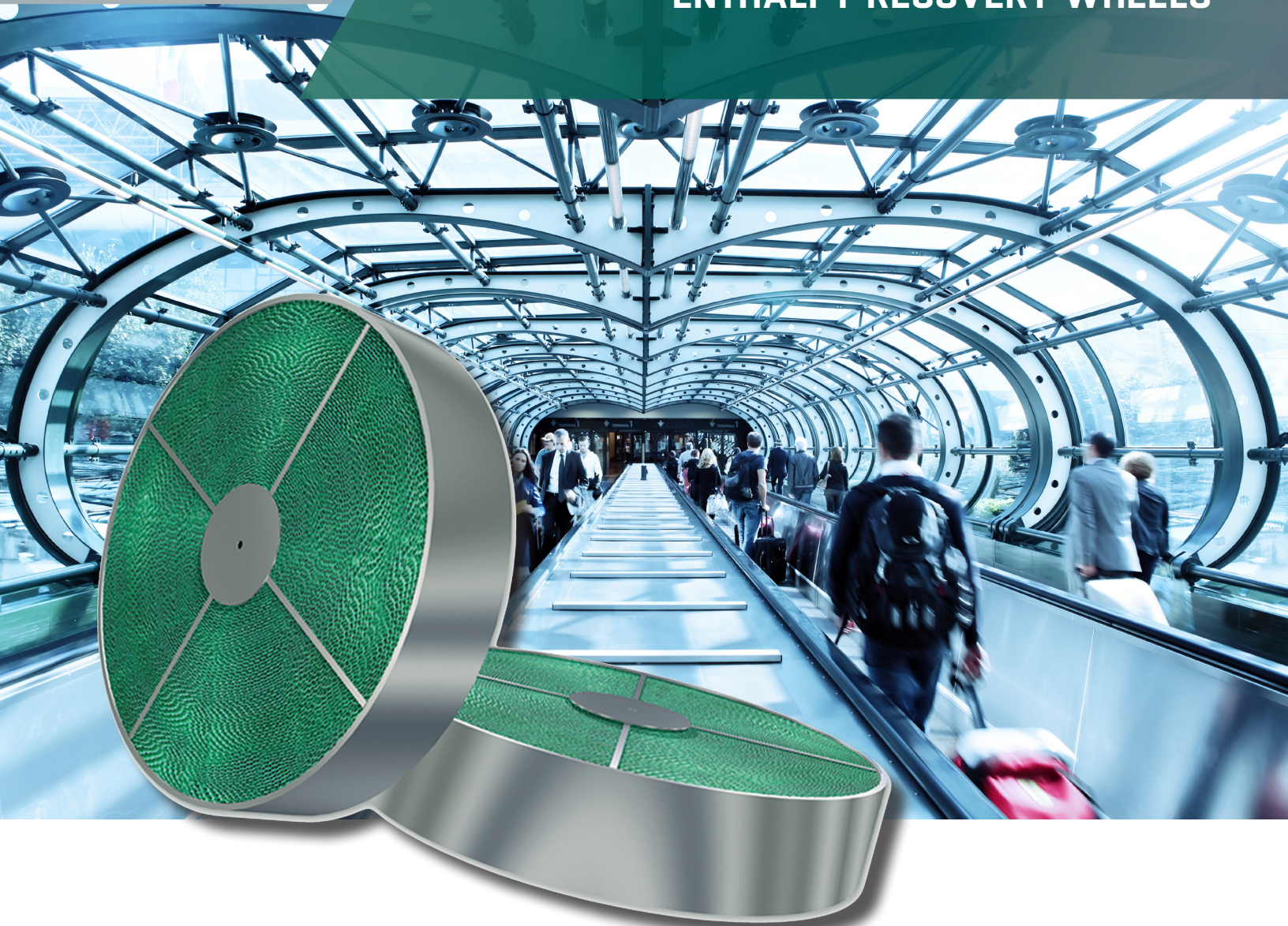

# FLÄKTGROUP® SEMCO® WHEEL TECHNOLOGY OFFERS A NUMBER OF BENEFITS

FläktGroup® SEMCO® offers a wide selection of original equipment manufacturer (OEM) desiccant wheel products and systems that can increase the performance of a variety of energy recovery products. Our OEM products offer the highest performance, and maintain the lowest operating cost. The ability to recover latent energy is one of the major benefits of the FläktGroup SEMCO wheel technology. FläktGroup SEMCO wheels provide the perfect solution to *ASHRAE Standard 62, Ventilation for Acceptable Indoor Air Quality*, with airflow capacities which range from 900 CFM to 70,000 CFM.



- Independently tested and AHRI certified superior wheel performance
- Highest latent and sensible heat transfer efficiencies
- Highest Recovery Efficiency Ratios — RER— available (energy saved less energy expended to save it).
- Industry leading indoor air quality device through minimized desiccant cross contamination
- Integrated purge section option
- Wheel independently certified to pass NFPA 90A requirements for flame spread and smoke generation and ASTM E84 fire test method
- Proven reliable operation
- Low maintenance
- Low operating costs
- Proven long life expectancy

## APPLICATIONS:

- SCHOOLS, UNIVERSITIES, DORMITORIES
- OFFICES, CONDOMINIUMS, APARTMENTS
- SMOKING LOUNGES, CASINOS
- NURSING HOMES, DAY CARE CENTERS
- HOTELS, MOTELS, DEPARTMENT STORES
- BREWERIES
- SPORTS ARENAS
- CONVENTION CENTERS, AIRPORTS, PRISONS
- BUS AND TRAIN MAINTENANCE FACILITIES
- WELDING, FOUNDRY, CASTING AREAS
- PRINTING OPERATIONS
- ALL HUMIDITY CONTROLLED SPACES



AHRI certified and independently tested wheel performance



Highest industry specifiable latent effectiveness and Recovery Efficiency Ratio — RER



Reliable operation and long life expectancy backed by 40 years of proven product performance

# WHY FLÄKTGROUP® SEMCO® PRODUCTS OPTIMIZE SYSTEMS

# SEMCO VS. COMPETITION

**REASON 1: WE DELIVER HIGH TOTAL RECOVERY EFFECTIVENESS WITH LOW PARASITIC PRESSURE LOSS TO MINIMIZE THE INSTALLED HEATING AND COOLING CAPACITY, REDUCE FAN MOTOR SIZE WHILE MAXIMIZING OVERALL SYSTEM PERFORMANCE AND CLIENT ENERGY SAVINGS.**

Energy recovery wheels that are not optimized feature low latent performance, require increased cooling capacities, need deeper coils and frost more easily during cold weather. Conversely, recovery wheels designed to operate with high air pressure losses, significantly impact fan brake horsepower requirements which erode much of the energy savings promised by the recovery device and result in lower EER ratings.

**REASON 2: WE ENABLE ENERGY RECOVERY SYSTEMS TO MAINTAIN A BETTER AND MORE CONSISTENT INDOOR AIR QUALITY FOR BUILDING OCCUPANTS**

All FläktGroup SEMCO wheels employ desiccant coatings which substantially reduce the amount of desiccant contaminant transfer when compared with other products, such as traditional silica gel wheels. Purge sections required to further limit contaminant transfer are a standard option for all FläktGroup SEMCO wheels.

FläktGroup SEMCO recovery wheels employ fluted aluminum media for true laminar flow and require minimal maintenance. They effectively operate with low efficiency filters without impacting the long-term performance of the recovery device. Recovery wheels that plug or require MERV 8 filters to protect against plugging negatively impact IAQ as increased internal static pressures diminish system airflows, especially with systems incorporating forward curve fans. Frequent and substantial reduction in the outdoor airflow is not in compliance with design codes and standards.

**REASON 3: ALLOWS COMPLIANCE WITH ASHRAE 90.1 2013 FAN LIMITATIONS AND ECONOMIZER REQUIREMENTS**

ASHRAE 90.1 2013 places strict limitations on the amount of fan horsepower that can be allocated to an energy recovery system. It also requires the

economizer airflow capability to equal 100% of the supply design airflow. The low pressure losses offered by the FläktGroup SEMCO wheels greatly simplifies the challenge of satisfying ASHRAE 90.1 2013 fan horsepower limitations and allows substantially more outdoor airflow to be delivered through a given size wheel during economizer mode.

**REASON 4: INCREASE THE AIRFLOW CAPABILITY AND/OR THE EXTERNAL STATIC PRESSURE CAPABILITY FROM AN EXISTING ERV**

Upgrading your ERV wheel with a FläktGroup SEMCO wheel, will provide immediate increased external static pressure capability and/or increased system airflow capacity. In many cases, smaller fan motor sizes can be installed while maintaining current product airflow capabilities and reducing the cost of electrical service. This lowers the manufacturing cost and increases product performance.

**REASON 5: SAFETY FIRST – BEATS NFPA 90A COMPLIANCE STANDARDS REQUIRING MINIMAL FLAME AND SMOKE GENERATION BY THE RECOVERY WHEEL MEDIA**

The FläktGroup SEMCO wheel media has been tested in accordance with ASTM E84 Standard Test Method for Surface Burning Characteristics of Building Materials or ANSI/UL 723 and shown to have a flame spread and a smoke generation of 0 and 0, well below the allowable limits of 25 and 50 respectively for all duct-mounted devices complying with NFPA 90A. SEMCO wheel products have also been tested for smoke generation and combustibility in accordance with UL-900, surpassing full compliance with results that were well below the criteria allowed.

**REASON 6: INCREASED RELIABILITY AND REDUCED MAINTENANCE**

FläktGroup SEMCO wheels have industrial duty gear motors with high quality, adjustable link belting to ensure a trouble free drive system. All wheels are relatively maintenance free, due to the self-cleaning media which resists plugging. This also prolongs the life of the wheel.

## FLÄKTGROUP® SEMCO® CLASSIC CASSETTE

### ENERGY SAVINGS COMPARISON

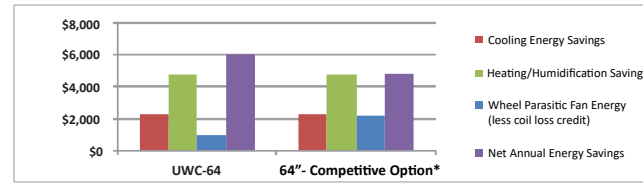

Comparison for SEMCO UWC 64 vs 64" competitive option using Atlanta weather conditions, \$10 for electricity and \$5.00 per million BTU for gas 8,000 cfm supply and return airflows, continuous operation

Plant Capacity Savings	UWC-64	64" - Competitive Option*
Total Effectiveness	64.5%	64.5%
Supply Air Pressure Loss	0.51 inwg	0.51 inwg
Return Air Pressure Loss	0.51 inwg	0.94 inwg

Here is the difference in performance values between the two products based on AHRI listings

### RER COMPARISON

RER <sub>total</sub> Comparison	UWC-68	64" - Competitive Option
Cooling RER <sub>total</sub>	121.4	67.9
Heating RER <sub>total</sub>	206.1	115.2

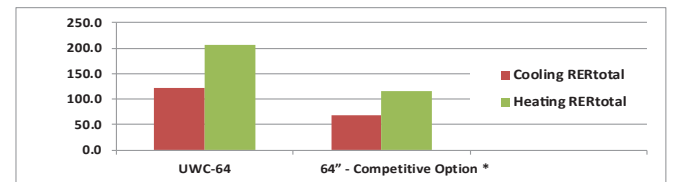

## FLÄKTGROUP® SEMCO® CROSS CASSETTE 4

### ENERGY SAVINGS COMPARISON

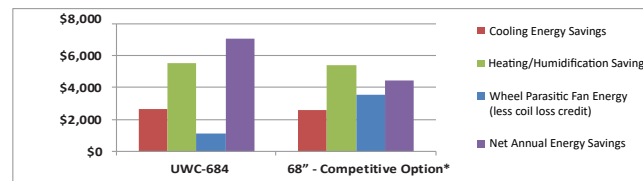

Comparison for SEMCO UWC-684 vs competitive 68" option using Atlanta weather conditions, \$10 for electricity and \$5.00 per million BTU for gas 8,000 cfm supply and return airflows, continuous operation

Plant Capacity Savings	UWC-684	ECW-664" - Competitive Option*
Total Effectiveness	64.6%	63.0%
Supply Air Pressure Loss	0.51 inwg	1.25 inwg
Return Air Pressure Loss	0.51 inwg	1.25 inwg

Here is the difference in performance values between the two products based on AHRI listings

### RER COMPARISON

RER <sub>total</sub> Comparison	UWC-68	64" - Competitive Option
Cooling RER <sub>total</sub>	123.1	50.1
Heating RER <sub>total</sub>	208.9	85.0

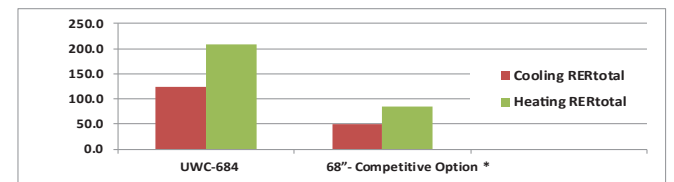

## FLÄKTGROUP® SEMCO® FUSION CASSETTE

### ENERGY SAVINGS COMPARISON

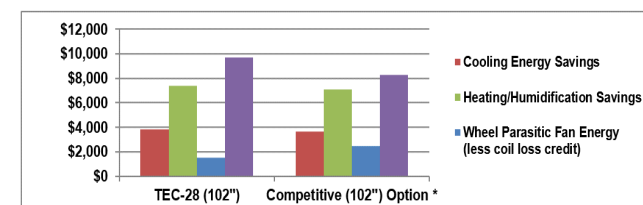

Comparison for SEMCO TEC-28 vs Competitive 102" wheel using Atlanta weather conditions, \$10 for electricity and \$5.00 per million BTU for gas 16,000 cfm supply and return airflows

Plant Capacity Savings	TEC-28 (102")	102" - Competitive Option*
Total Effectiveness	75.0%	71.5%
Supply Air Pressure Loss	0.56 inwg	0.80 inwg
Return Air Pressure Loss	0.56 inwg	0.80 inwg

Here is the difference in performance values between the two products based on AHRI listings

### RER COMPARISON

RER <sub>total</sub> Comparison	UWC-68	64" - Competitive Option
Cooling RER <sub>total</sub>	123.1	50.1
Heating RER <sub>total</sub>	208.9	85.0

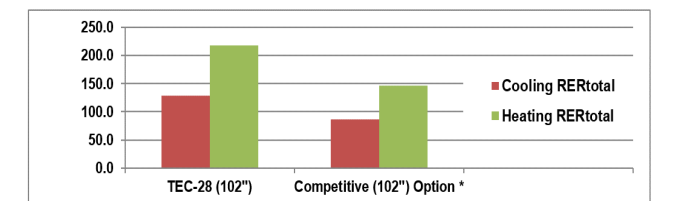

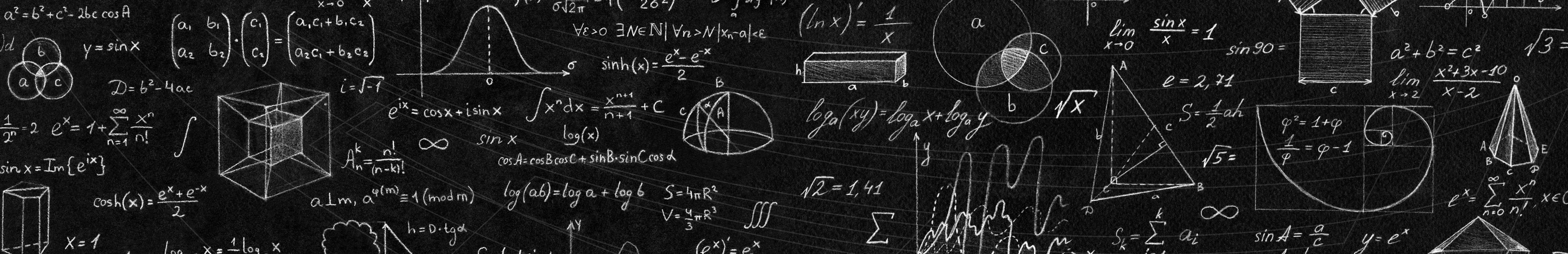

## PRODUCT DESCRIPTION

As an HVAC professional, you know that outdoor air quantity is important because more outdoor air means better quality air for those in the building—which means better cognitive function, reduced odors, less illness and reduced allergens. However, you also know that treating more air tends to go hand in hand with higher energy costs. FläktGroup SEMCO's Fusion Series has an answer to this.

FläktGroup SEMCO's Fusion Series wheel line is designed to pre-cool and dehumidify the outdoor air during the cooling season as well as preheat and humidify the outdoor air during the heating season. Ultimately, the outdoor air quantity can be increased from 5 to 20 CFM per person without increasing the total energy costs. The FläktGroup SEMCO Fusion wheel line delivers the highest total energy recovery performance and recovery efficiency ratios (RER) of any certified 200 mm deep recovery wheels available today.

And while we are discussing costs, with the added efficiency of the Fusion wheel, HVAC professionals can reduce the size of the chillers, boilers, humidifiers and pumps required for the job. These size reductions equate to cost reductions that often more than pays for any additional cost associated with the installation of the total energy recovery equipment.

FläktGroup SEMCO's Fusion Series is ideal for applications requiring airflow capacities ranging from 1,000 CFM to 70,000 CFM, and the line is made up of SEMCO's standard Fusion wheels and FläktGroup SEMCO's Fusion 3A wheels. Both lines optimize total recovery performance and wheel pressure loss, and the Fusion 3A wheels have the added benefit of also greatly limiting contaminate transfer, providing further improvements in indoor air quality for commercial applications.

And last, when you buy a FläktGroup SEMCO wheel, you can expect it to perform at or above its published performance levels—every time.\* When looking for OEM wheels, be sure to compare the FläktGroup SEMCO AHRI certified data with other recovery wheel options to

ensure that you receive the benefits that superior performance provides.

\*Within the accuracy limits of field measured performance

The FläktGroup SEMCO standard Fusion wheel line optimizes total recovery performance and wheel pressure loss, but keeps your manufacturing costs low. This wheel line has been designed for projects where the degree of contaminant transfer is considered unimportant and where low cost is considered more important than better indoor air quality.

## fusion

And though it is not FläktGroup SEMCO's top of the line contaminant limiter, the standard Fusion wheel does incorporate a proprietary zeolite composite coating and provides a contaminant carry-over performance that is superior to that offered by non-molecular sieve based wheels such as those employing silica gel.

Standard FläktGroup SEMCO Fusion wheels have been specifically developed for OEM manufacturers and are ideal for applications requiring 1,000 CFM to 70,000 CFM in a single wheel cassette.

### STANDARD PRODUCT FEATURES:

- Industry's highest recovery performance (AHRI Certified) and Recovery Efficiency Ratios (RER)
- 200 mm deep transfer media
- Reduced contaminant carry-over compared to silica gel based energy wheels
- Structural steel tubing-support casing to limit deflection (Size 9 and greater)
- Extruded aluminum structural hub, spokes and rim system
- Comprehensive variable speed wheel DDC controls and sensors

The FläktGroup SEMCO Fusion 3A wheel is the most consistent, high-performing 3A OEM wheel on the market today. The Fusion 3A line has been developed to optimize total recovery performance and wheel pressure loss, while limiting desiccant contaminant carry-over in a manner on par with or better than other 3A molecular sieve wheels. The Fusion 3A has been designed for projects where limiting contaminant transfer is desired but achieving competitive bidding is considered more important.

## fusion 3A

The Fusion 3A incorporates the same high-grade 3A molecular sieve and binding system used to produce the SEMCO's top of the line True 3Å wheel.\* However, the Fusion 3A is produced without the use of FläktGroup SEMCO's proprietary 27-step process necessary to achieve true 3 angstrom behavior. While the Fusion 3A does not limit contaminant carry-over to the degree possible with the FläktGroup SEMCO True 3Å wheel, the cost of manufacturing the product is significantly reduced, allowing us to offer our OEM customers the reliability of a FläktGroup SEMCO wheel that is price-competitive to second-tier 3A products while providing superior performance. \* The FläktGroup SEMCO True 3Å is not available to OEM customers at this time.

### APPLICATION LIMITATIONS:

Recommended for non-critical applications where limiting contaminant transfer is desired. Non-critical applications can be defined by ASHRAE 62 Class 1 or Class 2 spaces where contamination transfer levels should be limited below 10%. This would include applications where the exhaust air stream contained chemicals with mild odors such as toilet exhaust. The Fusion 3A is available to OEM customers on a job by job basis where FläktGroup SEMCO can evaluate the specific needs of critical applications and ensure a successful project for the OEM, the end user, and FläktGroup SEMCO.

### STANDARD PRODUCT FEATURES:

- Industry's highest recovery performance (AHRI Certified) and Recovery Efficiency Ratios (RER)
- 200 mm deep transfer media
- Reduced contaminant carry-over – equal to or better than other competitors' wheels marketed as using a 3A molecular sieve (See **FIGURE 1**)
- Anti-corrosion face coating standard
- Structural steel tubing support casing to limit deflection
- Extruded aluminum structural hub, spokes and rim system
- Comprehensive variable speed wheel DDC controls

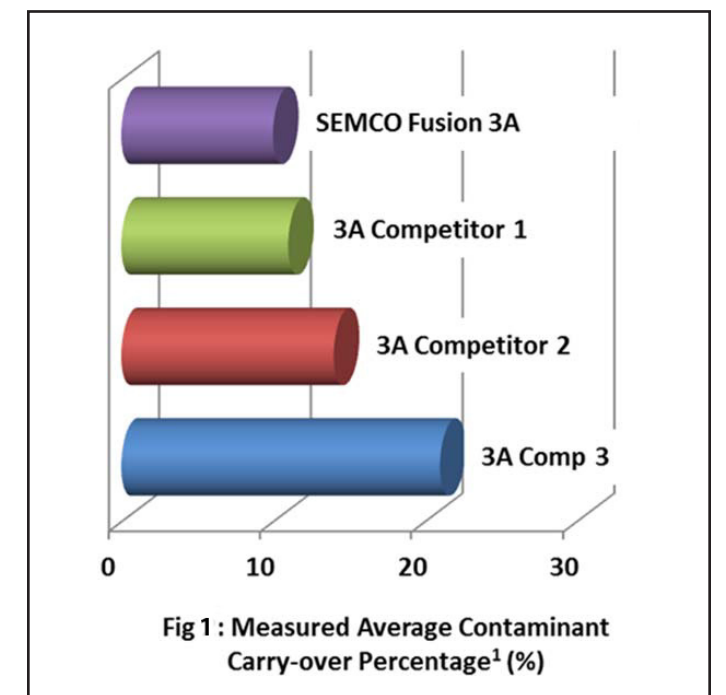

**FIGURE 1:** Results based upon laboratory testing showing average contaminant carry-over for eight different chemical families. ASHRAE 84 procedures followed, contaminant families chosen by Georgia Tech Research Institute (GTRI)

# FUSION SERIES

## PERFORMANCE DATA & DIMENSIONS

# CONTROLS

## INFORMATION & FEATURES

### PERFORMANCE DATA FOR FUSION AND FUSION 3A WHEELS

VELOCITY FPM	EFFECTIVENESS %	PRESS. DROP IN.WG	Air Flow Rate (in CFM) ↓	MODEL NUMBER										
				TEC-3	TEC-5	TEC-9	TEC-13	TEC-18	TEC-24	TEC-28	TEC-35	TEC-43	TEC-46	TEC-56
200	83.80	0.24	840	1,590	2,580	3,930	5,430	7,140	8,490	10,560	12,870	13,920	16,800	21,120
300	81.22	0.33	1,120	2,120	3,440	5,240	7,240	9,520	11,320	14,080	17,160	18,560	22,400	28,160
400	78.64	0.42	1,400	2,650	4,300	6,550	9,050	11,900	14,150	17,600	21,450	23,200	28,000	35,200
500	76.05	0.52	1,680	3,180	5,160	7,860	10,860	14,280	16,980	21,120	25,740	27,840	33,600	42,240
600	73.47	0.62	1,960	3,710	6,020	9,170	12,670	16,660	19,810	24,640	30,030	32,480	39,200	49,280
700	70.89	0.73	2,240	4,420	6,880	10,480	14,480	19,040	22,640	28,160	34,320	37,120	44,800	56,320
800	68.31	0.84	2,520	4,770	7,740	11,790	16,290	21,420	25,470	31,680	38,610	41,760	50,400	63,360
900	65.73	0.96	2,800	5,300	8,600	13,100	18,100	23,800	28,300	35,200	42,900	46,400	56,000	70,400
1000	63.15	1.09	3,080	5,830	9,460	14,410	19,910	26,180	31,130	38,720	47,190	51,040	61,600	77,440

### FUSION AND FUSION 3A WHEEL UNIT DIMENSIONS

#### SIZES 13 - 70

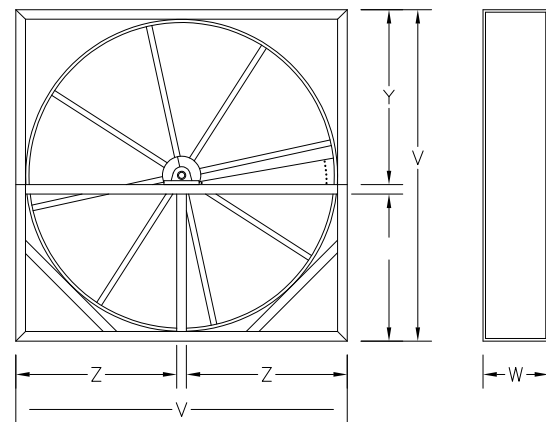

#### SIZES 3, 5 AND 9

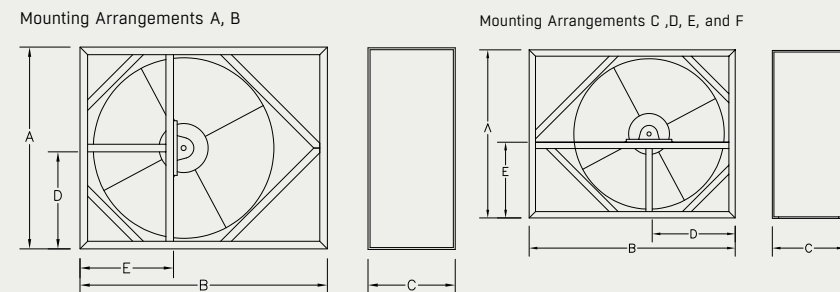

MODEL NUMBER	DIMENSIONS (INCHES)					NET WT. (LBS.)	FLOW AREA / SIDE, FT²	NOMINAL CFM
	A	B	C	D	E			
TEC-3	39.8	48.8	17.25	19.2	18.4	330	2.8	2,000
TEC-5	51.8	58.2	17.25	25.2	24.4	450	5.3	4,000
TEC-9	63.8	70.2	17.25	31.2	30.4	600	8.6	7,000

MODEL NUMBER	DIMENSIONS (INCHES)					NET WT. (LBS.)	FLOW AREA / SIDE, FT²	NOMINAL CFM
	V	W	X	Y	Z			
TEC-13	75.8	18.25	33.8	40.0	36.9	940	13.1	10,500
TEC-18	87.8	18.25	39.8	46.0	42.9	1140	18.1	15,500
TEC-24	99.8	18.25	45.8	52.0	48.9	1420	23.8	19,000
TEC-28	111.8	20.25	49.8	59.0	54.4	2370	28.3	22,500
TEC-35	123.8	20.25	55.8	65.0	60.4	2685	35.2	28,000
TEC-43	135.8	20.25	61.8	71.0	66.4	3025	42.9	34,000
TEC-46	141.0	20.25	64.4	73.6	69.0	3180	46.2	37,000
TEC-56	154.0	20.25	70.9	80.1	75.5	3580	56.0	45,000
TEC-70	171.5	20.25	79.6	88.9	84.3	4140	70.4	56,000

### WHEEL CONTROL PACKAGE

FläktGroup® SEMCO® provides a controller, rotation detector board, keypad, and terminal strip mounted in a Nema 1 enclosure. Four point style temperature sensors, the wheel variable frequency drive, and rotation detector pickup ship loose.

#### FACTORY CONTROLS PACKAGES INCLUDE THE FOLLOWING COMPONENTS BY FLÄKTGROUP SEMCO:

- Wheel gearmotor and VFD
- I/O Zone 583 Controller
- BACview5 2 row x 20 column keypad
- Four point temperature sensors to be mounted in the outdoor, supply, extract, and exhaust air stream
- Rotation detector

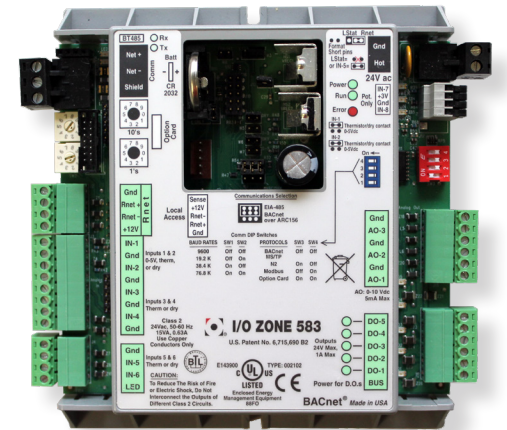

#### CONTROL FUNCTIONALITY

- Supply temperature based variable wheel speed control
- Wheel condensation control
- Rotation alarm
- BACnet MS/TP, ARC156, Modbus or N2 communications

### WHEEL CONTROL PACKAGE UPGRADES

When chosen, this package includes all of the functionality of the wheel control package with the addition of humidity based discharge control and an upgraded wheel control strategy.

#### INCLUDES ALL OF THE WHEEL CONTROL PACKAGE WITH ADDITIONS OR UPGRADES AS FOLLOWS:

- I/O Zone 583 Controller upgrade to I/O Flex 6126
- Keypad upgrade to BACview6 4 row x 40 column
- Two point temperature sensors to be mounted in the supply and exhaust air streams
- Two combination temperature/RH sensors to be mounted in the outdoor and extract air streams
- Enthalpy based summer/winter changeover
- Automatic condensation control set point

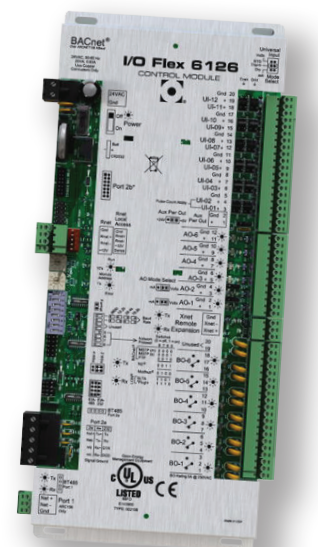



## PRODUCT DESCRIPTION

You now can have the quality and performance of a FläktGroup SEMCO energy recovery wheel in your existing OEM wheel application. The UWC line recovers both sensible and latent energy, and does more effectively than any competitive offerings. The UWC series provides the perfect solution to upgrade or replace the plastic disposable wheel in your ERU. These wheels can be found in Aeon®, Greenheck®, Carrier Corporation®, ClimateMaster®, Lennox®, McQuay International®, and other manufacturers' energy recovery units.

FläktGroup SEMCO offers two different cassette options, the **CLASSIC CASSETTE** and the **CROSS CASSETTE**. Both lines feature the same quality and performance, customers have come to expect from a FläktGroup SEMCO wheel.

The **CLASSIC CASSETTE**, which launched in the market in 2014, features narrower cassette dimensions.

The **CROSS CASSETTE** line is offered with both 4" and 6" media depths, and the cassette dimensions are broader than the **CLASSIC CASSETTE** line.

The performance edge is a result of UWC line's unique transfer core. The fluted opening design utilizes a sturdy, but lightweight, all-aluminum wheel substrate coated with a fast-acting, corrosion-resistant, proprietary desiccant. The fluted design efficiently produces maximum latent and sensible air-to-air heat transfer, but generates up to 50% less HVAC system static pressure than polymer film wheels.

The UWC line provides the perfect solution to *ASHRAE Standard 62, Ventilation for Acceptable Indoor Air Quality*. Airflow capacities range from 700 CFM to 32,000 CFM.

UWC 3A delivers the highest total energy recovery performance and recovery efficiency ratio (RER) of any certified 100 mm recovery wheel available.

## SUPERIOR PERFORMANCE

Highest latent and sensible heat transfer efficiency certified media.

## COMPACT DESIGN

Most compact design in the industry given any specific face velocity and efficiency.  
**\*\*Based on industry standard 400-900 feet per minute**

## AHRI CERTIFIED

Independently tested in accordance with ASHRAE 84 and verified to assure the equipment will perform accurately and consistently.



## MONEY SAVING

Fast adsorption of moisture, giving a high latent efficiency even at high air flow rates.

## EXCEEDS SMOKE AND FLAME SPREAD SAFETY RATINGS

The UWC line is independently certified to pass NFPA 90A requirements for flame spread and smoke generation based upon ASTM E84 fire test method.

## CORROSION RESISTANCE

The ceramic coating on the rotor gives extremely high corrosion protection.

## UNIQUE FLUTE DESIGN

Generating the highest possible heat transfer characteristics while simultaneously reducing pressure loss parameters, resulting in a reduction of brake horsepower used and fan size.

## NON-OXIDIZED COATED MEDIA

The media is made from aluminum which features a dense layer of corrosion resistant desiccant. This extends the life of the aluminum media substrate and enhances its structural integrity, perimeter and face contact seals to minimize air leakage and wheel bypass.

## LOW LEAKAGE SEALS

The UWC line is supplied with hybrid brush/barrier, perimeter and face contact seals to minimize air leakage and wheel bypass, forming the ideal sealing surface.

## LIGHT WEIGHT MEDIA SUPPORT

The media support members (hub, spokes and rims) are aluminum extrusions. This combines strength with precision.

## EASE OF INSTALLATION

The UWC is designed to be a slide in replacement for the stacked plate, dimpled plastic wheels in most applications and can be easily installed in just a few minutes.



Whether you already have a FläktGroup® SEMCO® air handling unit, and need a replacement, or have one of our competitor's units, and want to upgrade your UWC to the best in the industry, we have a wheel that meets your needs. Check the reference chart below, to find the perfect wheel for your air handling unit.

## FLÄKTGROUP® SEMCO® CONVERSION CHART

Classic Cassette Series	AirXChange®	Cross Cassette 4 Series	NovelAire® 4"	Cross Cassette 6 Series	NovelAire® 6"
UWC-36	ERC-36	UWC-364	ECW-364	UWC-526	ECW-546
UWC-41	ERC-41	UWC-414	ECW-424	UWC-586	ECW-606
UWC-46	ERC-46	UWC-464	ECW-484	UWC-686	ECW-666
UWC-52	ERC-52	UWC-524	ECW-544	UWC-746	ECW-726
UWC-58	ERC-58	UWC-584	ECW-604	UWC-786	ECW-786
UWC-64	ERC-64	UWC-684	ECW-664	UWC-846	ECW-846
UWC-68	ERC-68	UWC-744	ECW-784	UWC-906	ECW-906
UWC-74	ERC-74	UWC-784	ECW-784	UWC-966	ECW-966
UWC-78	ERC-81	UWC-844	UWC-844	UWC-1026	ECW-1026
UWC-84	ERC-86	—	—	UWC-1086	ECW-1086

© 2024 Airxchange Inc. All Rights Reserved, © 2022 NovelAire Technologies All Rights Reserved

# CLASSIC CASSETTE

## PERFORMANCE DATA AND DIMENSIONS

### CLASSIC CASSETTE DATA

VELOCITY (SFPM)	EFFECTIVENESS			PRESSURE LOSS (INWG)
	SENSIBLE	LATENT	TOTAL	
300	72	74	73	0.20
400	70	70	71	0.25
500	68	67	69	0.31
600	66	64	67	0.39
700	64	61	65	0.47
800	62	58	62	0.56
900	60	55	60	0.65

**CLASSIC CASSETTE** media employs a larger flute size, resulting in lower pressure loss and performance at the lowest product cost.

### CLASSIC HIGH EFFICIENCY CASSETTE DATA

VELOCITY (SFPM)	EFFECTIVENESS			PRESSURE LOSS (INWG)
	SENSIBLE	LATENT	TOTAL	
300	76	76	76	0.29
400	73	74	73	0.36
500	71	72	72	0.46
600	69	69	69	0.57
700	67	67	67	0.69
800	65	64	64	0.82
900	63	61	62	0.94

**CLASSIC HIGH EFFICIENCY CASSETTE** media employs a smaller flute size, resulting in higher recovery performance at a slightly higher pressure loss and product cost.

VELOCITY (SFPM)	DIMENSIONS (INCHES)									
	UWC-36	UWC-41	UWC-46	UWC-52	UWC-58	UWC-64	UWC-68	UWC-74	UWC-78	UWC-84
300	930	1,230	1,560	2,130	2,760	3,210	3,750	4,440	4,860	5,640
400	1,240	1,640	2,080	2,840	3,680	4,280	5,000	5,920	6,480	7,520
500	1,550	2,050	2,600	3,550	4,600	5,350	6,250	7,400	8,100	9,400
600	1,860	2,460	3,120	4,260	5,520	6,440	7,500	8,880	9,720	11,280
700	2,170	2,870	3,640	4,970	6,440	7,360	8,750	10,360	11,340	13,160
800	2,480	3,280	4,160	5,680	7,360	8,560	10,000	11,840	12,960	15,040
900	2,790	3,690	4,680	6,390	8,280	9,630	11,250	13,320	14,580	16,920

### CLASSIC CASSETTE AND CLASSIC HIGH EFFICIENCY CASSETTE DIMENSIONS: 30 AND LARGER

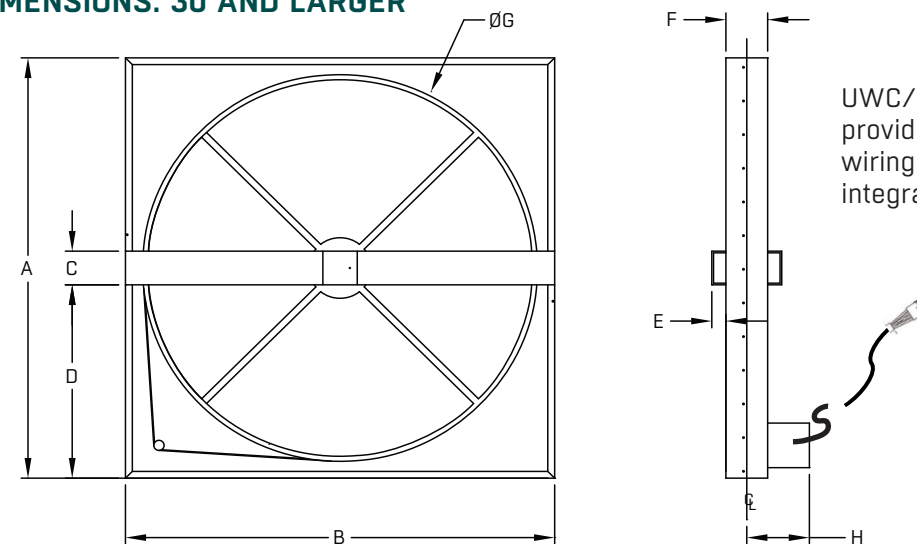

MODEL #	DIMENSIONS (INCHES)											UWC NET WEIGHT (LBS)	UWCH NET WEIGHT (LBS)
	A	B	C	D	E	F	G	H (NOTE 1)	J	K	TOTAL WIDTH		
UWC-36	39.80	39.80	2.82	18.40	1.31	4.36	36	5.5 (1)	N/A	N/A	8.99	130	138
UWC-41	44.00	44.00	3.10	20.50	1.58	4.36	41	5.5 (1)	N/A	N/A	9.26	158	168
UWC-46	50.00	50.00	3.10	23.50	1.58	4.36	46	5.5 (1)	N/A	N/A	9.26	177	189
UWC-52	56.19	56.19	3.10	26.50	1.58	4.36	52	5.5 (1)	N/A	N/A	9.26	201	216
UWC-58	62.42	62.42	3.10	29.70	2.05	4.36	58	7.5	N/A	N/A	14.04	238	257
UWC-64	68.00	68.00	5.00	31.50	2.05	6.07	64	7.5	N/A	N/A	12.59	247	270
UWC-68	72.00	72.00	6.00	33.00	2.05	7.07	68	7.5	N/A	N/A	13.09	262	288
UWC-74	78.00	78.00	6.00	36.00	2.05	7.07	74	7.5	N/A	N/A	13.09	285	316
UWC-78	85.00	85.00	6.00	39.5	2.14	7.07	78	10.5	N/A	N/A	16.18	617	652
UWC-84	91.00	91.00	7.00	42.0	2.99	10.0	84	10.5	N/A	N/A	18.49	715	750

**NOTE 1:** Add 2" to "H Dimension" for the following applications: Constant Speed - 220V/1PH or 575V/3PH, Variable Speed - 460V/3PH or 575V/3PH

# CLASSIC CASSETTE MOTORS

# CLASSIC CASSETTE MOTOR MATRIX

## POSITION

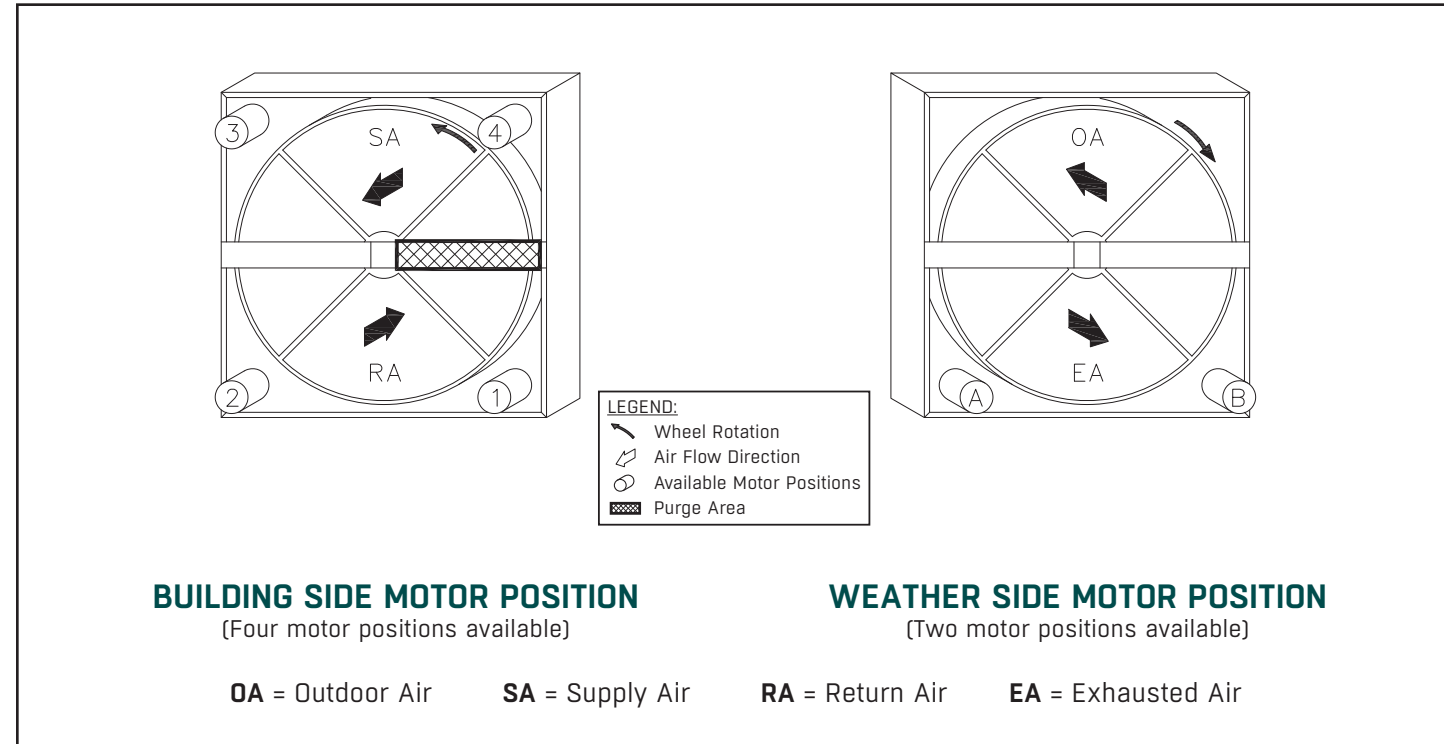

- The crosshatch section shown on the bearing support bar drawing is the location of the optional purge section
- The optional purge is always positioned on the building side of the wheel.
- Available motor positions are fixed as indicated on the drawings. For example, If the wheel is rotated 180° such that supply is on the bottom, motor position 1 is now located at the top left corner.
- Motor positions 1, 2, 3, and 4 are on the building side of the wheel. Motor position A and B are on the weather side of the wheel (opposite of 1 and 2 respectively)

CLASSIC CASSETTE MOTOR MATRIX		CONSTANT SPEED OPERATION				INVERTER DRIVEN VARIABLE SPEED OPERATION <sup>(2)</sup>		
MODEL #	MOTOR DETAILS	220V/1PH	208-230V/3PH	460V/3PH	575V/3PH	208-230/3PH	460V/3PH	575V/3PH <sup>(2)</sup>
UWC-36	Motor Model	GF18N005-BMYJ5C	GF15N005-BMRF2C	GF15N005-BMRF3C	G3K18N005-BMH8A	GF15N005-BMRF2C	G3K18N005-BMH4A	G3K18N005-BMH4A
	Horsepower Amps	1/6 0.85 amps	1/15 0.38 amps	1/15 0.17 amps	1/8 0.20 amps	1/15 0.38 amps	1/8 0.29 amps	1/8 0.29 amps
UWC-41	Motor Model	GF18N005-BMYJ5C	GF15N005-BMRF2C	GF15N005-BMRF3C	G3K18N005-BMH8A	GF15N005-BMRF2C	G3K18N005-BMH4A	G3K18N005-BMH4A
	Horsepower Amps	1/6 0.85 amps	1/15 0.38 amps	1/15 0.17 amps	1/8 0.20 amps	1/15 0.38 amps	1/8 0.29 amps	1/8 0.29 amps
UWC-46	Motor Model	GF18N005-BMYJ5C	GF15N005-BMRF2C	GF15N005-BMRF3C	G3K18N005-BMH8A	GF15N005-BMRF2C	G3K18N005-BMH4A	G3K18N005-BMH4A
	Horsepower Amps	1/6 0.85 amps	1/15 0.38 amps	1/15 0.17 amps	1/8 0.20 amps	1/15 0.38 amps	1/8 0.29 amps	1/8 0.29 amps
UWC-52	Motor Model	GF18N005-BMYJ5C	GF15N005-BMRF2C	GF15N005-BMRF3C	G3K18N005-BMH8A	GF15N005-BMRF2C	G3K18N005-BMH4A	G3K18N005-BMH4A
	Horsepower Amps	1/6 0.85 amps	1/15 0.38 amps	1/15 0.17 amps	1/8 0.20 amps	1/15 0.38 amps	1/8 0.29 amps	1/8 0.29 amps
UWC-58	Motor Model	N/A	GF18N005-BMYJ2C	GF18N005-BMYJ3C	G3K18N005-BMH8A	GF18N005-BMYJ2C	G3K18N005-BMH4A	G3K18N005-BMH4A
	Horsepower Amps	N/A	1/6 0.64 amps	1/6 0.31 amps	1/8 0.20 amps	1/6 0.64 amps	1/8 0.29 amps	1/8 0.29 amps
UWC-64	Motor Model	N/A	GF18N005-BMYJ2C	GF18N005-BMYJ3C	G3K18N005-BMH8A	GF18N005-BMYJ2C	G3K18N005-BMH4A	G3K18N005-BMH4A
	Horsepower Amps	N/A	1/6 0.64 amps	1/6 0.31 amps	1/8 0.20 amps	1/6 0.64 amps	1/8 0.29 amps	1/8 0.29 amps
UWC-68	Motor Model	N/A	GF18N005-BMYJ2C	GF18N005-BMYJ3C	G3K18N005-BMH8A	GF18N005-BMYJ2C	G3K18N005-BMH4A	G3K18N005-BMH4A
	Horsepower Amps	N/A	1/6 0.64 amps	1/6 0.31 amps	1/8 0.20 amps	1/6 0.64 amps	1/8 0.29 amps	1/8 0.29 amps
UWC-74	Motor Model	N/A	GF18N005-BMYJ2C	GF18N005-BMYJ3C	G3K18N005-BMH8A	GF18N005-BMYJ2C	G3K18N005-BMH4A	G3K18N005-BMH4A
	Horsepower Amps	N/A	1/6 0.64 amps	1/6 0.31 amps	1/8 0.20 amps	1/6 0.64 amps	1/8 0.29 amps	1/8 0.29 amps
UWC-78	Motor Model	N/A	G3K22N5-MF4AENTZ	G3K22N5-MF4AENTZ	N/A	G3K22N5-MF4AENTZ	G3K22N5-MF4AENTZ	N/A
	Horsepower Amps	N/A	1/2 1.8 amps	1/2 0.9 amps	N/A	1/2 1.8 amps	1/2 0.9 amps	N/A
UWC-84	Motor Model	N/A	G3K22N5-MF4AENTZ	G3K22N5-MF4AENTZ	N/A	G3K22N5-MF4AENTZ	G3K22N5-MF4AENTZ	N/A
	Horsepower Amps	N/A	1/2 1.8 amps	1/2 0.9 amps	N/A	1/2 1.8 amps	1/2 0.9 amps	N/A

- NOTE 1:** Proper motor class and inverter setup parameters are critical for proper variable speed motor operation. Preconfigured inverter from SEMCO recommended. For details please see page 20.
- NOTE 2:** Use 575V inverter. Program inverter for max 460 volts output.
- NOTE 3:** All wheels are equipped with 16" motor wiring lead with male Amp connector. The single phase, three wire, wire colors are black (3), green (2), and white (1). The three phase, four wire, wire colors are black (4), white (3), red (2), and green (1).

## CLASSIC CASSETTE AND CLASSIC HIGH EFFICIENCY CASSETTE CONFIGURATIONS AND MOTOR POSITIONS

The **CLASSIC AND CLASSIC HIGH EFFICIENCY CASSETTES** are offered to fit most configurations required by the OEM customer. The simple yet flexible design allows the OEM customer to rotate the wheel drawing on page into the appropriate orientation, then select the desired motor position from the options shown. To ensure proper performance, the **CLASSIC AND CLASSIC HIGH EFFICIENCY CASSETTES**, must be installed such that the wheel sections labeled as Supply Air and Outdoor Air are in the appropriate sections within the energy recovery unit – ERU – and the wheel rotation direction must be confirmed.



# CROSS CASSETTE 4

## PERFORMANCE DATA AND DIMENSIONS

PERFORMANCE DATA FOR CROSS CASSETTE 4

VELOCITY FPM	EFFECTIVENESS %	PRESS. DROP IN.WG	Air Flow Rate (in CFM)	WHEEL SIZE				
				UWC-364	UWC-414	UWC-464	UWC-524	UWC-584
300	73	0.20		930	1,230	1,560	2,130	2,130
400	70	0.25		1,240	1,640	2,080	2,840	3,680
500	68	0.31		1,550	2,050	2,600	3,550	4,600
600	66	0.39		1,860	2,460	3,120	4,260	5,520
700	63	0.47		2,170	2,870	3,640	4,970	6,440
800	61	0.56		2,480	3,280	4,160	5,680	7,360
900	59	0.65		2,790	3,690	4,680	6,390	8,280

PERFORMANCE DATA FOR CROSS CASSETTE 4

VELOCITY FPM	EFFECTIVENESS %	PRESS. DROP IN.WG	Air Flow Rate (in CFM)	WHEEL SIZE			
				UWC-684	UWC-744	UWC-784	UWC-844
300	73	0.20		3,750	4,440	4,860	5,640
400	70	0.25		5,000	5,920	6,480	7,520
500	68	0.31		6,250	7,400	8,100	9,400
600	66	0.39		7,500	8,880	9,720	11,280
700	63	0.47		8,750	10,360	11,340	13,160
800	61	0.56		10,000	11,840	12,960	15,040
900	59	0.65		11,250	13,320	14,580	16,920

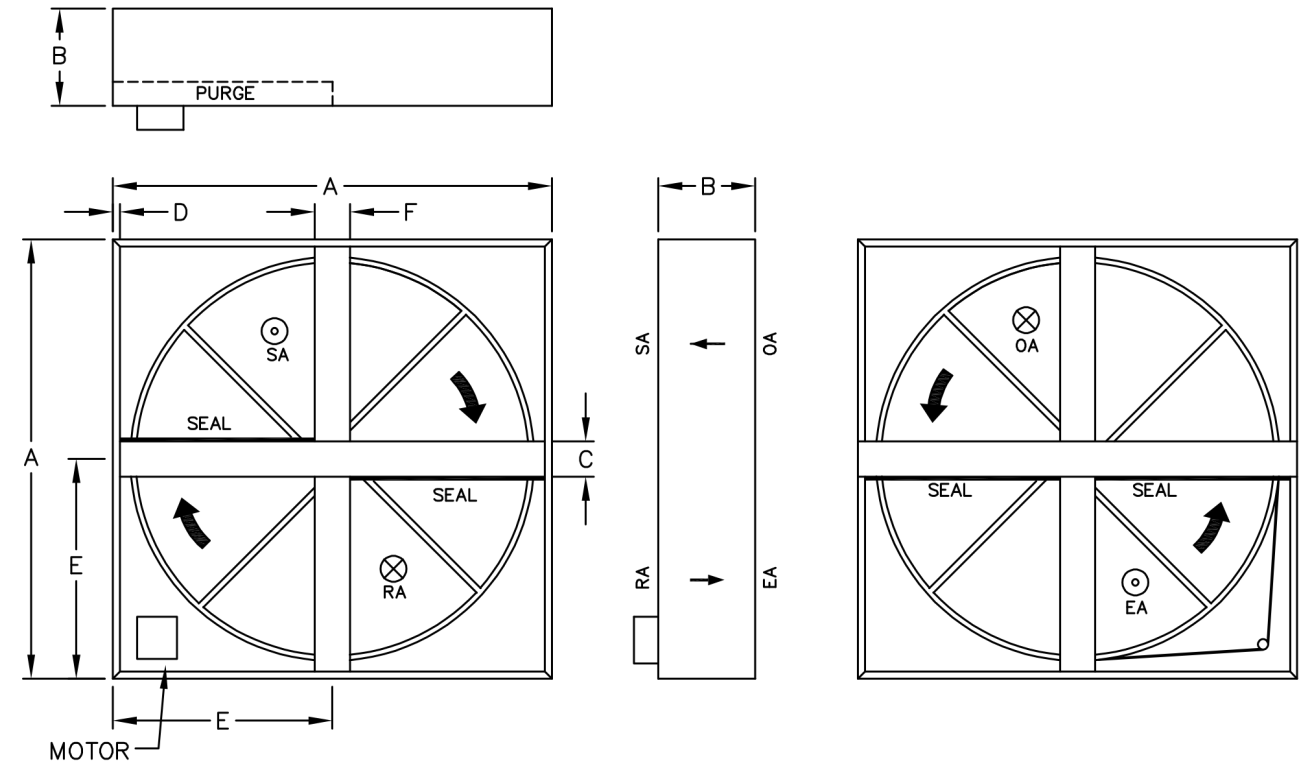
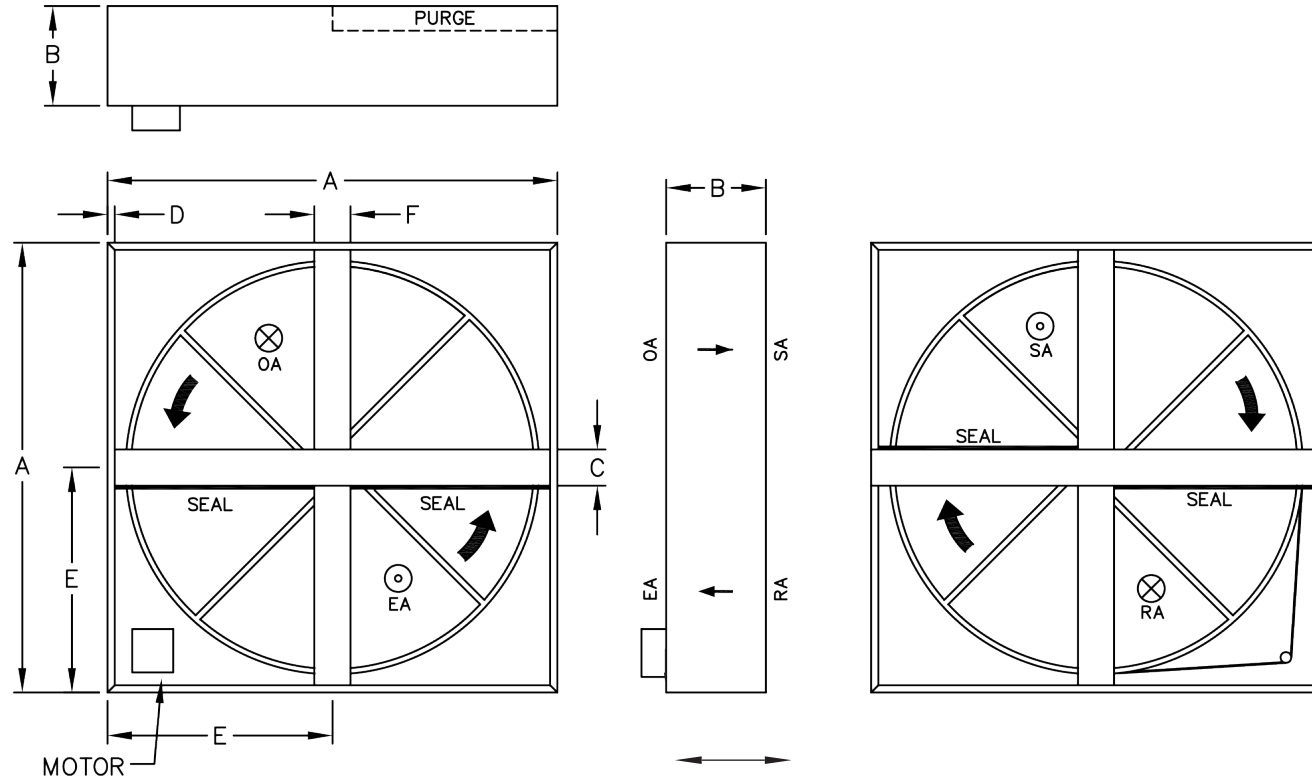

MODEL #	WHEEL DEPTH	DIMENSIONS (INCHES)						NET WT. (LBS.)	NOMINAL CFM
		A	B	C	D	E	F		
UWC-364	3.75"	44.00"	7.00"	2.50"	1.00"	22.00"	2.60"	138	2300
UWC-414	3.75"	48.00"	7.00"	2.50"	1.00"	24.00"	2.60"	176	3000
UWC-464	3.75"	54.00"	8.00"	2.75"	2.00"	27.00"	2.90"	224	3900
UWC-524	3.75"	60.00"	8.00"	2.75"	2.00"	30.00"	2.90"	282	5000
UWC-584	3.75"	66.00"	8.00"	2.75"	2.00"	33.00"	2.90"	347	6200

MODEL #	WHEEL DEPTH	DIMENSIONS (INCHES)						NET WT. (LBS.)	NOMINAL CFM
		A	B	C	D	E	F		
UWC-684	3.75"	72.00"	9.00"	4.00"	1.50"	36.00"	4.20"	472	8600
UWC-744	3.75"	78.00"	9.00"	4.00"	1.50"	39.00"	4.20"	555	10200
UWC-784	3.75"	84.00"	9.50"	5.00"	2.00"	42.00"	4.50"	620	11300
UWC-844	3.75"	90.00"	9.50"	5.00"	2.00"	45.00"	4.50"	715	13200

# CROSS CASSETTE 4 MOTOR MATRIX

# CROSS CASSETTE 6 MOTOR MATRIX

CROSS CASSETTE 4 MOTOR MATRIX		CONSTANT SPEED OPERATION				INVERTER DRIVEN VARIABLE SPEED OPERATION <sup>(1)</sup>		
MODEL #	MOTOR DETAILS	220V/1PH	208-230V/3PH	460V/3PH	575V/3PH	208-230/3PH	460V/3PH	575V/3PH <sup>(2)</sup>
UWC-364	Motor Model GF18N005- BMRE5C Horsepower 1/20 Amps 0.31	GF15N005- BMR2C 1/15 0.38	GF15N005- BMR3C 1/15 0.17	GF18N005- BMH8A 1/8 0.20	GF15N005- BMR2C 1/15 0.38	G3K18N5- MF1AENXTZ 1/8 0.29	G3K18N005- BMH8A 1/8 0.20	
UWC-414	Motor Model GF18N005- BMYJ5C Horsepower 1/6 Amps 0.85	GF15N005- BMR2C 1/15 0.38	GF15N005- BMR3C 1/15 0.17	GF18N005- BMH8A 1/8 0.20	GF15N005- BMR2C 1/15 0.38	G3K18N5- MF1AENXTZ 1/8 0.29	G3K18N005- BMH8A 1/8 0.20	
UWC-464	Motor Model GF18N005- BMYJ5C Horsepower 1/6 Amps 0.85	GF15N005- BMR2C 1/15 0.38	GF15N005- BMR3C 1/15 0.17	GF18N005- BMH8A 1/8 0.20	GF15N005- BMR2C 1/15 0.38	G3K18N5- MF1AENXTZ 1/8 0.29	G3K18N005- BMH8A 1/8 0.20	
UWC-524	Motor Model GF18N005- BMYJ5C Horsepower 1/6 Amps 0.85	GF15N005- BMR2C 1/15 0.38	GF15N005- BMR3C 1/15 0.17	GF18N005- BMH8A 1/8 0.20	GF15N005- BMR2C 1/15 0.38	G3K18N5- MF1AENXTZ 1/8 0.29	G3K18N005- BMH8A 1/8 0.20	
UWC-584	Motor Model N/A Horsepower Amps	N/A	GF18N005- BMYJ2C 1/6 0.64	GF18N005- BMYJ3C 1/6 0.31	G3K18N005- BMH8A 1/8 0.20	GF18N005- BMYJ2C 1/6 0.64	G3K18N5- MF1AENXTZ 1/8 0.29	G3K18N005- BMH8A 1/8 0.20
UWC-684	Motor Model N/A Horsepower Amps	N/A	GF18N005- BMYJ2C 1/6 0.64	GF18N005- BMYJ3C 1/6 0.31	GF18N005- BMH8A 1/8 0.20	GF18N005- BMYJ2C 1/6 0.64	G3K18N5- MF1AENXTZ 1/8 0.29	G3K18N005- BMH8A 1/8 0.20
UWC-744	Motor Model N/A Horsepower Amps	N/A	GF18N005- BMYJ2C 1/6 0.64	GF18N005- BMYJ3C 1/6 0.31	GF18N005- BMH8A 1/8 0.20	GF18N005- BMYJ2C 1/6 0.64	G3K18N5- MF1AENXTZ 1/8 0.29	G3K18N005- BMH8A 1/8 0.20
UWC-784	Motor Model N/A Horsepower Amps	N/A	G3K18N5- MF2AENTZ 1/4 1.0	G3K18N5- MF2AENTZ 1/4 0.5	N/A	G3K18N5- MF2AENTZ 1/4 1.0	G3K18N5- MF2AENTZ 1/4 0.5	N/A
UWC-844	Motor Model N/A Horsepower Amps	N/A	G3K18N5- MF2AENTZ 1/4 1.0	G3K18N5- MF2AENTZ 1/4 0.5	N/A	G3K18N5- MF2AENTZ 1/4 1.0	G3K18N5- MF2AENTZ 1/4 0.5	N/A

**NOTE 1:** Proper motor class and inverter setup parameters are critical for proper variable speed motor operation. Preconfigured inverter from SEMCO recommended. For details please see page 20.

**NOTE 2:** Use 575V inverter. Program inverter for max 460 volts output.

**NOTE 3:** All wheels are equipped with 16" motor wiring lead with male Amp connector. The single phase, three wire, wire colors are black (3), green (2), and white (1). The three phase, four wire, wire colors are black (4), white (3), red (2), and green (1).

CROSS CASSETTE 6 MOTOR MATRIX		CONSTANT SPEED OPERATION			INVERTER DRIVEN VARIABLE SPEED OPERATION <sup>(1)</sup>	
MODEL #	MOTOR DETAILS	220V/1PH	208-230V/3PH	460V/3PH	208-230/3PH	460V/3PH
UWC-466	Motor Model GF18N005- BMYJ5C Horsepower 1/6 Amps 0.85	GF18N005- BMYJ2C 1/6 0.64	GF18N005- BMYJ3C 1/6 0.31	GF15N005- BMR2C 1/15 0.38	GF15N005- BMR2C 1/15 0.38	G3K18N005- BMH8A 1/8 0.20
UWC-526	Motor Model GF18N005- BMYJ5C Horsepower 1/6 Amps 0.85	GF18N005- BMYJ2C 1/6 0.64	GF18N005- BMYJ3C 1/6 0.31	GF15N005- BMR2C 1/15 0.38	GF15N005- BMR2C 1/15 0.38	G3K18N005- BMH8A 1/8 0.20
UWC-586	Motor Model N/A Horsepower Amps	N/A	GF18N005- BMYJ2C 1/6 0.64	GF18N005- BMYJ3C 1/6 0.31	GF18N005- BMYJ2C 1/6 0.64	G3K18N005- BMH8A 1/8 0.20
UWC-686	Motor Model N/A Horsepower Amps	N/A	G3K18N5- MF2AENTZ 1/4 1.0	G3K18N5- MF2AENTZ 1/4 0.5	G3K18N5- MF2AENTZ 1/4 1.0	G3K18N5- MF2AENTZ 1/4 0.5
UWC-746	Motor Model N/A Horsepower Amps	N/A	G3K18N5- MF2AENTZ 1/4 1.0	G3K18N5- MF2AENTZ 1/4 0.5	GF18N5- MF2AENTZ 1/4 1.0	G3K18N5- MF2AENTZ 1/4 0.5
UWC-786	Motor Model N/A Horsepower Amps	N/A	G3K18N5- MF2AENTZ 1/4 1.0	G3K18N5- MF2AENTZ 1/4 0.5	G3K18N5- MF2AENTZ 1/4 1.0	G3K18N5- MF2AENTZ 1/4 0.5
UWC-846	Motor Model N/A Horsepower Amps	N/A	G3K18N5- MF2AENTZ 1/4 1.0	G3K18N5- MF2AENTZ 1/4 0.5	G3K18N5- MF2AENTZ 1/4 1.0	G3K18N5- MF2AENTZ 1/4 0.5
UWC-906	Motor Model N/A Horsepower Amps	N/A	G3K18N5- MF2AENTZ 1/4 1.0	G3K18N5- MF2AENTZ 1/4 0.5	G3K18N5- MF2AENTZ 1/4 1.0	G3K18N5- MF2AENTZ 1/4 0.5
UWC-966	Motor Model N/A Horsepower Amps	N/A	G3K18N5- MF2AENTZ 1/4 1.0	G3K18N5- MF2AENTZ 1/4 0.5	G3K18N5- MF2AENTZ 1/4 1.0	G3K18N5- MF2AENTZ 1/4 0.5
UWC-1026	Motor Model N/A Horsepower Amps	N/A	G3K18N5- MF2AENTZ 1/4 1.0	G3K18N5- MF2AENTZ 1/4 0.5	G3K18N5- MF2AENTZ 1/4 1.0	G3K18N5- MF2AENTZ 1/4 0.5
UWC-1086	Motor Model N/A Horsepower Amps	N/A	G3K18N5- MF2AENTZ 1/4 1.0	G3K18N5- MF2AENTZ 1/4 0.5	G3K18N5- MF2AENTZ 1/4 1.0	G3K18N5- MF2AENTZ 1/4 0.5

**NOTE 1:** Proper motor class and inverter setup parameters are critical for proper variable speed motor operation. Preconfigured inverter from SEMCO recommended. For details please see page 20.

**NOTE 2:** Use 575V inverter. Program inverter for max 460 volts output.

**NOTE 3:** All wheels are equipped with 16" motor wiring lead with male Amp connector. The single phase, three wire, wire colors are black (3), green (2), and white (1). The three phase, four wire, wire colors are black (4), white (3), red (2), and green (1).

# CROSS CASSETTE 6

## PERFORMANCE DATA AND DIMENSIONS

### PERFORMANCE DATA FOR THE CROSS CASSETTE 6

VELOCITY FPM	EFFECTIVENESS %	PRESS. DROP IN.WVG	Air Flow Rate (in CFM) ↓	MODEL NUMBER										
				UWC-466	UWC-526	UWC-586	UWC-686	UWC-746	UWC-786	UWC-846	UWC-906	UWC-966	UWC-1026	UWC-1086
400	76	0.36		2,160	2,800	3,480	4,840	5,720	6,400	7,440	8,560	9,760	11,040	14,120
500	73	0.47		2,700	3,500	4,350	6,050	7,150	8,000	9,300	10,700	12,200	13,800	17,640
600	71	0.58		3,240	4,200	5,220	7,260	8,580	9,600	11,160	12,850	14,650	16,550	21,180
700	68	0.71		3,780	4,900	6,090	8,470	10,010	11,200	13,020	14,980	17,080	19,320	24,720
800	66	0.84		4,320	5,600	6,960	9,680	11,440	12,800	14,880	17,080	19,530	22,090	28,250
900	63	0.97		4,860	6,300	7,830	10,890	12,870	14,400	16,740	19,320	21,950	24,840	31,760

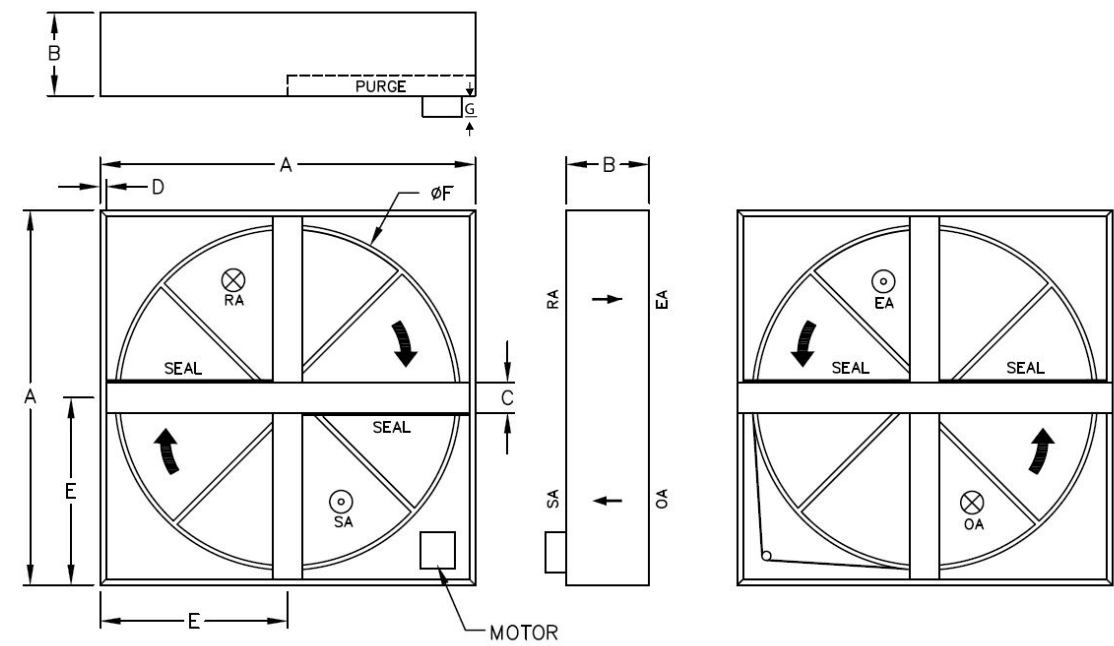

MODEL #	WHEEL DEPTH	DIMENSIONS (INCHES)						NET WT. (LBS.)	NOMINAL CFM
		A	B	C	D	E	F		
UWC-686	6.00"	72"	11.00"	4.00"	1.50"	36.00"	4.20"	431	8,500
UWC-746	6.00"	78"	11.00"	4.00"	1.50"	39.00"	4.20"	508	10,000
UWC-786	6.00"	84"	12.00"	5.00"	2.00"	42.00"	4.60"	566	11,200
UWC-846	6.00"	90"	12.00"	5.00"	2.00"	45.00"	4.60"	655	13,000
UWC-906	6.00"	96"	12.00"	6.00"	2.00"	48.00"	4.60"	750	15,000
UWC-966	6.00"	102"	12.00"	6.00"	2.00"	51.00"	4.60"	852	17,100
UWC-1026	6.00"	108"	12.00"	6.00"	2.00"	54.00"	4.60"	962	19,300

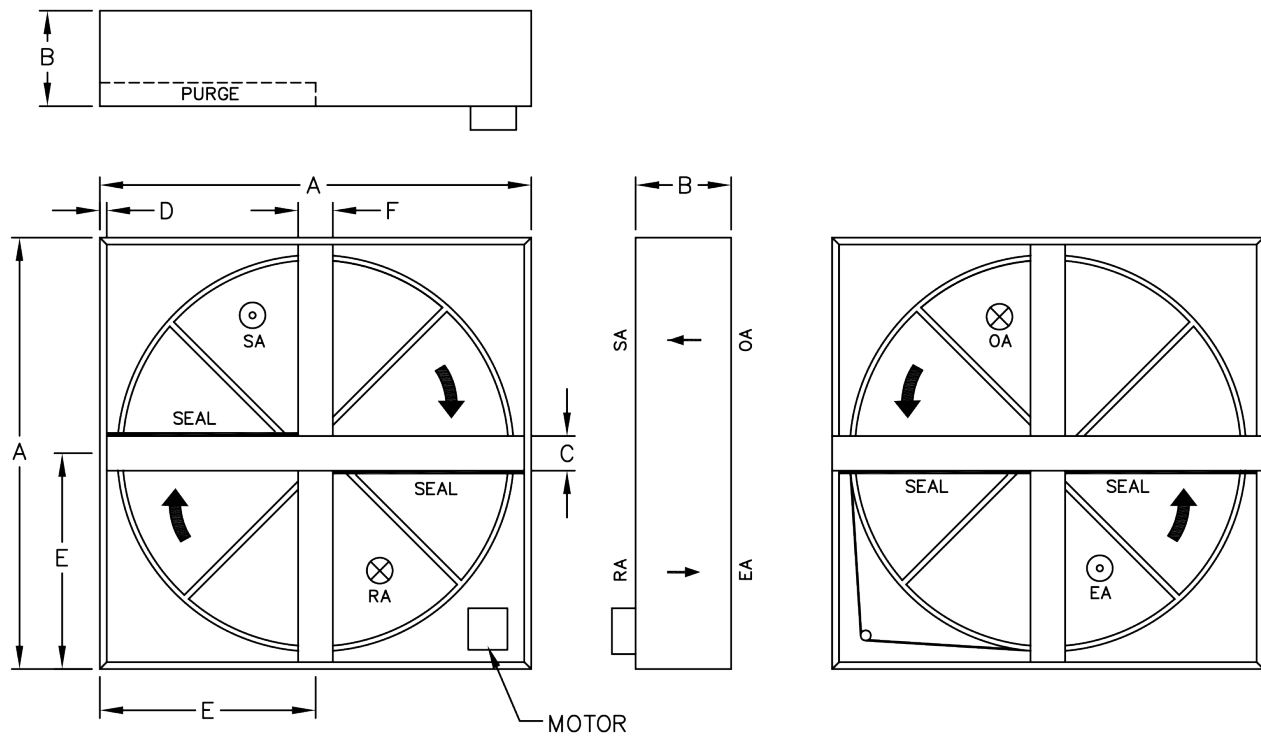

MODEL #	WHEEL DEPTH	DIMENSIONS (INCHES)						NET WT. (LBS.)	NOMINAL CFM
		A	B	C	D	E	F		
UWC-466	6.00"	54.00"	10.00"	2.75"	2.00"	27.00"	2.9"	203	3,800
UWC-526	6.00"	60.00"	10.00"	2.75"	2.00"	30.00"	2.9"	256	4,900
UWC-586	6.00"	66.00"	10.00"	2.75"	2.00"	33.00"	2.9"	316	6,100

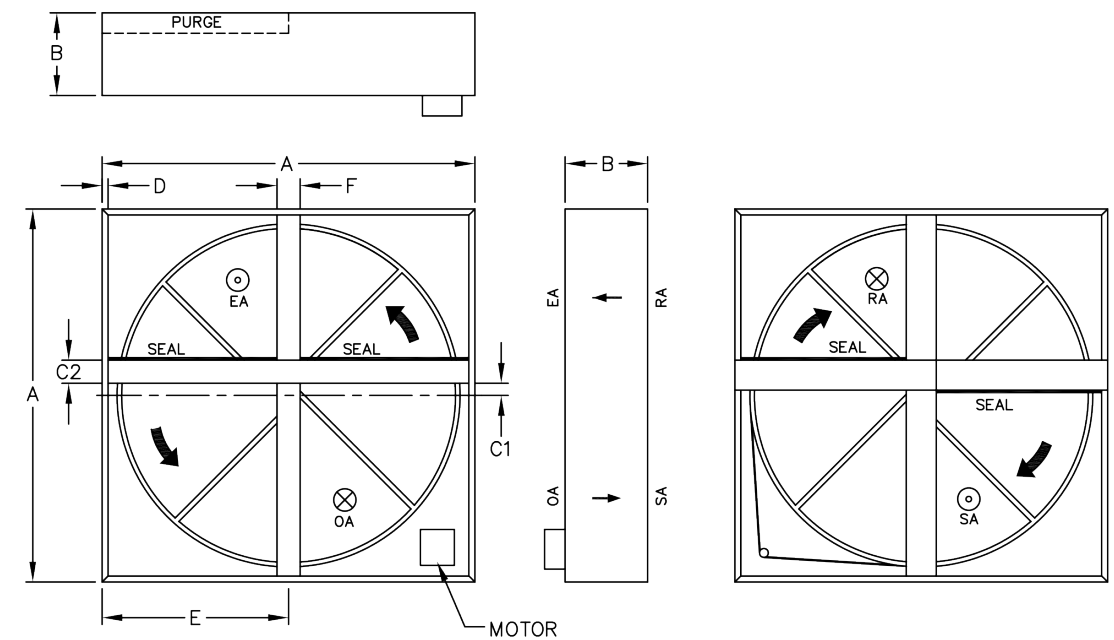

MODEL #	WHEEL DEPTH	DIMENSIONS (INCHES)							NET WT. (LBS.)	NOMINAL CFM
		A	B	C1	C2	D	E	F		
UWC-1086	6.00"	116.25"	14.63"	6.87"	2.75"	2.00"	58.13"	4.60"	1078	24,700

## SOFTWARE AND SUPPORT

- DLL performance software for integration into the selection software of OEM customers
- Stand-alone software for product selection, analysis and sales support which provides:
  - A) Selection guidance based on airflow
  - B) Performance data for cooling and heating conditions at any selected conditions
  - C) Easy energy analysis calculations for various U.S. cities complete with graphical output suitable for providing to the clients or engineers of OEM customers
  - D) RER calculations
  - E) Performance schedules for the total energy recovery wheels
  - F) Frost alarm warnings and recommendations when variable wheel frost control is employed
  - G) Full submittal output if desired
- Numerous certifications and independent test reports on product performance
- 40 years of application knowledge and expertise



## PRODUCT FEATURES:

- Industry's highest recovery performance (AHRI Certified) and Recovery Efficiency Ratios (RER)
- 100-150 mm deep transfer media
- Reduced contaminant carry-over compared to silica gel based energy wheels
- Structural sheet metal with tubular bearing support
- Structural aluminum media spoke system with extruded aluminum inner hub
- Comprehensive variable speed wheel motor (optional)

## TOTAL ENERGY RECOVERY WHEEL

The rotor media must be made of aluminum which is formed into a fluted, honeycomb matrix which and coated to prohibit corrosion; paper, fibrous or plastic medias are not acceptable. All surfaces must be coated with a non-migrating zeolite desiccant composite designed to maximize latent recovery while reducing the transfer of airborne contaminants, which are often times abundant in silica gel or oxidized aluminum recovery wheels. The wheel media shall be a permanent component with an estimated 20 year life and not a "throw away" item. The component should be suitable for integration within units incorporating heating sources of all types without damage and designed to accommodate operating conditions up to 180°F.

The recovery wheel product performance must be AHRI certified. Submitted data must be based upon this certified data, meeting or exceeding the temperature and latent efficiencies scheduled. The wheel pressure loss data must not exceed that scheduled for the supply and return air streams. The product performance must also meet or exceed the design heating and cooling RER (recovery efficiency ratio) values listed within the schedule.

The recovery media must have been independently tested by a recognized laboratory to show compliance with UL-900 requirements with regard to smoke generation and combustibility. A full copy of the UL-900 test report must be provided for review with submittals.

The recovery wheel media can be cleaned with low temperature steam, hot water or light detergent without degrading the latent recovery.

## PURGE SECTOR

The unit must be available with a purge sector designed to limit cross-contamination of the exhaust air stream concentration when operated under appropriate design conditions.

## ROTOR SEALS

The rotor shall be supplied with pre-adjusted low leakage hybrid brush seals to separate the two air streams

## ROTOR SUPPORT SYSTEM

The rotor media must be re-enforced with an aluminum structural spoke system, extruded central hub and shaft sized to limit deflection and to ensure long-term structural integrity.

## UNIT HOUSING

The rotor housing must be designed to limit deflection of the rotor due to air pressure loss. The sheet metal panels shall be made of galvanized steel to prevent corrosion. The rotor shall be supported by internal sealed bearings that are permanently lubricated to reduce maintenance requirements.

## DRIVE SYSTEM

The drive system, must be driven by a reinforced, industrial grade adjustable link belt system. Plastic stretch belts are not acceptable. An A/C gear motor specifically designed for high torque, low speed operation is utilized for constant and variable speed applications.

The 460 volt motors supplied for inverter duty have been specifically designed for achieving long life in inverter driven applications, are NEMA MG1 Section IV Part 31 compliant and have UL/CSA/CE/RoHS certifications.

## SOLE AND EXCLUSIVE WARRANTY

Please see the terms and conditions for your order or contact [service.semco@flaktgroup.com](mailto:service.semco@flaktgroup.com).



# EXCELLENCE IN SOLUTIONS

WWW.SEMCOHVAC.COM

OEM WHEEL / 20240103

FläktGroup® SEMCO® delivers smart, energy-efficient, air-quality solutions to support every building application. We offer our customers innovative technologies, high-quality products and outstanding performance supported by more than fifty years of accumulated industry experience. The broadest offering on the market and a strong market presence in 65 countries worldwide guarantees that we are always by your side, ready to deliver:

## FläktGroup® SEMCO®

Corporate Headquarters  
1800 East Pointe Drive  
Columbia, Missouri 65201 USA

573.443.1481

sales.semco@flaktgroup.com

To learn more about FläktGroup® SEMCO® offerings and to contact your nearest representative please visit

[www.semcohvac.com](http://www.semcohvac.com)



© Copyright 2024 SEMCO LLC. All Rights Reserved. SEMCO embraces a policy of continuous development and improvement, the right is reserved to supply products which may differ from those illustrated and described in this publication. Specifications are subject to change without further notice. Any FläktGroup SEMCO purchase is subject to FläktGroup SEMCO standard terms and conditions. Certified dimensions will be supplied upon request on receipt of order. SEMCO is a registered Trademark of SEMCO LLC. Other trademarks and logos in this publication may be property of SEMCO, LLC, its subsidiaries or any of its related companies and/or other organizations or individuals. U.S. patented technology. AirXChange® is a registered trademark of Airxchange Inc. NovelAire® is a registered trademark of NovelAire Technologies, AADN® is a registered trademark of Aaon® GREENHECK® is a registered trademark of Greenheck Fan Corp®, Carrier Corporation® is a registered trademark of UTC Climate Controls and Security® a Unit of United Technologies Corp® CLIMATEMASTER® is a registered trademark of ClimateMaster Inc.®, LENNOX® is a registered trademark of Lennox International Inc.®, McQuay International® is a registered trademark of McQuay Air-Conditioning, LTD.®, DAIKIN® is a registered trademark of Daikin Industries, LTD®.

Trane® is a registered trademark of Trane International Inc.

