

INDOOR AIR QUALITY

ENERGY RECOVERY

UNITARY WHEEL CASSETTES



FLÄKTGROUP® SEMCO® WHEEL TECHNOLOGY OFFERS A NUMBER OF BENEFITS

FläktGroup® SEMCO® offers a wide selection of original equipment manufacturer (OEM) desiccant wheel products and systems that can increase the performance of a variety of energy recovery products. Our OEM products offer the highest performance, and maintain the lowest operating cost. The ability to recover latent energy is one of the major benefits of the Fläktgroup SEMCO wheel technology. FläktGroup SEMCO wheels provide the perfect solution to *ASHRAE Standard 62, Ventilation for Acceptable Indoor Air Quality*, with airflow capacities which range from 930 CFM to 70,000 CFM.



- Independently tested and AHRI certified superior wheel performance
- Highest latent and sensible heat transfer efficiencies
- Highest Recovery Efficiency Ratios — RER— available (energy saved less energy expended to save it).
- Industry leading indoor air quality device through minimized desiccant cross contamination
- Integrated purge section option
- Wheel independently certified to pass NFPA 90A requirements for flame spread and smoke generation and ASTM E84 fire test method
- Proven reliable operation
- Low maintenance
- Low operating costs
- Proven long life expectancy

APPLICATIONS:

- SCHOOLS, UNIVERSITIES, DORMITORIES
- OFFICES, CONDOMINIUMS, APARTMENTS
- SMOKING LOUNGES, CASINOS
- NURSING HOMES, DAY CARE CENTERS
- HOTELS, MOTELS, DEPARTMENT STORES
- BREWERIES
- SPORTS ARENAS
- CONVENTION CENTERS, AIRPORTS, PRISONS
- BUS AND TRAIN MAINTENANCE FACILITIES
- WELDING, FOUNDRY, CASTING AREAS
- PRINTING OPERATIONS
- ALL HUMIDITY CONTROLLED SPACES



AHRI certified and independently tested wheel performance



Highest industry specifiable latent effectiveness and Recovery Efficiency Ratio — RER



Reliable operation and long life expectancy backed by 40 years of proven product performance

FLÄKTGROUP SEMCO ADVANTAGE

FLÄKTGROUP SEMCO ADVANTAGE

You now can have the quality and performance of a FläktGroup SEMCO energy recovery wheel in your existing OEM wheel application. The UWC line recovers both sensible and latent energy, and does more effectively than any competitive offerings. The UWC series provides the perfect solution to upgrade or replace the plastic disposable wheel in your ERU. These wheels can be found in AAON®, GREENHECK®, Carrier Corporation®, CLIMATEMASTER®, LENNOX®, McQuay International®, and other manufacturers' energy recovery units.

Fläktgroup SEMCO offers two different cassette options, the **CLASSIC CASSETTE** and the **CROSS CASSETTE**. Both lines feature the same quality and performance, customers have come to expect from a FläktGroup SEMCO wheel.

The **CLASSIC CASSETTE**, which launched in the market in 2014, features narrower cassette dimensions.

The **CROSS CASSETTE** line is offered with both 4" and 6" media depths, and the cassette dimensions are broader than the **CLASSIC CASSETTE** line.

The performance edge is a result of UWC line's unique transfer core. The fluted opening design utilizes a sturdy, but lightweight, all-aluminum wheel substrate coated with a fast-acting, corrosion-resistant, proprietary desiccant. The fluted design efficiently produces maximum latent and sensible air-to-air heat transfer, but generates up to 50% less HVAC system static pressure than polymer film wheels.

The UWC line provides the perfect solution to *ASHRAE Standard 62, Ventilation for Acceptable Indoor Air Quality*. Airflow capacities range from 700 CFM to 32,000 CFM.

UWC 3A delivers the highest total energy recovery performance and recovery efficiency ratio (RER) of any certified 100 mm recovery wheel available.

SUPERIOR PERFORMANCE

Highest latent and sensible heat transfer efficiency certified media.

COMPACT DESIGN

Most compact design in the industry given any specific face velocity and efficiency.*
**Based on industry standard 400-900 feet per minute*

AHRI CERTIFIED

Independently tested in accordance with ASHRAE 84 and verified to assure the equipment will perform accurately and consistently.



MONEY SAVING

Fast adsorption of moisture, giving a high latent efficiency even at high air flow rates.

EXCEEDS SMOKE AND FLAME SPREAD SAFETY RATINGS

The UWC line is independently certified to pass NFPA 90A requirements for flame spread and smoke generation based upon ASTM E84 fire test method.

CORROSION RESISTANCE

The ceramic coating on the rotor gives extremely high corrosion protection.

UNIQUE FLUTE DESIGN

Generating the highest possible heat transfer characteristics while simultaneously reducing pressure loss parameters, resulting in a reduction of brake horsepower used and fan size.

NON-OXIDIZED COATED MEDIA

The media is made from aluminum which features a dense layer of corrosion resistant desiccant. This extends the life of the aluminum media substrate and enhances its structural integrity, perimeter and face contact seals to minimize air leakage and wheel bypass.

LOW LEAKAGE SEALS

The UWC line is supplied with hybrid brush/barrier, perimeter and face contact seals to minimize air leakage and wheel bypass, forming the ideal sealing surface.

LIGHT WEIGHT MEDIA SUPPORT

The media support members (hub, spokes and rims) are aluminum extrusions. This combines strength with precision.

EASE OF INSTALLATION

The UWC is designed to be a slide in replacement for the stacked plate, dimpled plastic wheels in most applications and can be easily installed in just a few minutes.

LIFETIME PERFORMANCE

The UWC is designed and built to provide long and reliable operation for the life of the equipment it's installed in, minimizing maintenance, labor and replacement costs. DLL performance software for integration into the selection software of OEM customers.

SOFTWARE AND SUPPORT

- Stand-alone software for product selection, analysis and sales support which provides:
 - A) Selection guidance based on airflow
 - B) Performance data for cooling and heating conditions at any selected conditions
 - C) Easy energy analysis calculations for various U.S. cities complete with graphical output suitable for providing to the clients or engineers of OEM customers
 - D) RER calculations
 - E) Performance schedules for the total energy recovery wheels
 - F) Frost alarm warnings and recommendations when variable wheel frost control is employed
 - G) Full submittal output if desired
- Numerous certifications and independent test reports on product performance

- 40 years of application knowledge and expertise



PRODUCT FEATURES:

- Industry's highest recovery performance (AHRI Certified) and Recovery Efficiency Ratios (RER)
- 100-150 mm deep transfer media
- Reduced contaminant carry-over compared to silica gel based energy wheels
- Structural sheet metal with tubular bearing support
- Structural aluminum media spoke system with extruded aluminum inner hub
- Comprehensive variable speed wheel motor (optional)

WHY SEMCO PRODUCTS OPTIMIZE SYSTEMS

SEMCO VS. COMPETITION

REASON 1: WE DELIVER HIGH TOTAL RECOVERY EFFECTIVENESS WITH LOW PARASITIC PRESSURE LOSS TO MINIMIZE THE INSTALLED HEATING AND COOLING CAPACITY, REDUCE FAN MOTOR SIZE WHILE MAXIMIZING OVERALL SYSTEM PERFORMANCE AND CLIENT ENERGY SAVINGS.

Energy recovery wheels that are not optimized feature low latent performance, require increased cooling capacities, need deeper coils and frost more easily during cold weather. Conversely, recovery wheels designed to operate with high air pressure losses, significantly impact fan brake horsepower requirements which erode much of the energy savings promised by the recovery device and result in lower EER ratings.

REASON 2: WE ENABLE ENERGY RECOVERY SYSTEMS TO MAINTAIN A BETTER AND MORE CONSISTENT INDOOR AIR QUALITY FOR BUILDING OCCUPANTS

All FläktGroup SEMCO wheels employ desiccant coatings which substantially reduce the amount of desiccant contaminant transfer when compared with other products, such as traditional silica gel wheels. Purge sections required to further limit contaminant transfer are a standard option for all FläktGroup SEMCO wheels.

FläktGroup SEMCO recovery wheels employ fluted aluminum media for true laminar flow and require minimal maintenance. They effectively operate with low efficiency filters without impacting the long-term performance of the recovery device. Recovery wheels that plug or require MERV 8 filters to protect against plugging negatively impact IAQ as increased internal static pressures diminish system airflows, especially with systems incorporating forward curve fans. Frequent and substantial reduction in the outdoor airflow is not in compliance with design codes and standards.

REASON 3: ALLOWS COMPLIANCE WITH ASHRAE 90.1 2013 FAN LIMITATIONS AND ECONOMIZER REQUIREMENTS

ASHRAE 90.1 2013 places strict limitations on the amount of fan horsepower that can be allocated to an energy recovery system. It also requires the

economizer airflow capability to equal 100% of the supply design airflow. The low pressure losses offered by the FläktGroup SEMCO wheels greatly simplifies the challenge of satisfying ASHRAE 90.1 2013 fan horsepower limitations and allows substantially more outdoor airflow to be delivered through a given size wheel during economizer mode.

REASON 4: INCREASE THE AIRFLOW CAPABILITY AND/OR THE EXTERNAL STATIC PRESSURE CAPABILITY FROM AN EXISTING ERV

Upgrading your ERV wheel with a FläktGroup SEMCO wheel, will provide immediate increased external static pressure capability and/or increased system airflow capacity. In many cases, smaller fan motor sizes can be installed while maintaining current product airflow capabilities and reducing the cost of electrical service. This lowers the manufacturing cost and increases product performance.

REASON 5: SAFETY FIRST – BEATS NFPA 90A COMPLIANCE STANDARDS REQUIRING MINIMAL FLAME AND SMOKE GENERATION BY THE RECOVERY WHEEL MEDIA

The FläktGroup SEMCO wheel media has been tested in accordance with ASTM E84 Standard Test Method for Surface Burning Characteristics of Building Materials or ANSI/UL 723 and shown to have a flame spread and a smoke generation of 0 and 0, well below the allowable limits of 25 and 50 respectively for all duct-mounted devices complying with NFPA 90A. SEMCO wheel products have also been tested for smoke generation and combustibility in accordance with UL-900, surpassing full compliance with results that were well below the criteria allowed.

REASON 6: INCREASED RELIABILITY AND REDUCED MAINTENANCE

FläktGroup SEMCO wheels have industrial duty gear motors with high quality, adjustable link belting to ensure a trouble free drive system. All wheels are relatively maintenance free, due to the self-cleaning media which resists plugging. This also prolongs the life of the wheel.

FLÄKTGROUP® SEMCO® CLASSIC CASSETTE

ENERGY SAVINGS COMPARISON

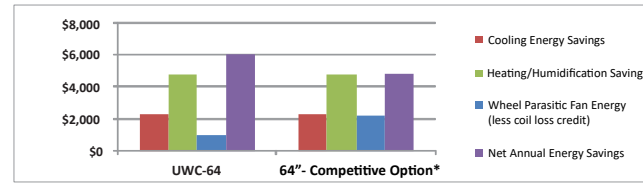

Comparison for SEMCO UWC 64 vs 64" competitive option using Atlanta weather conditions, \$10 for electricity and \$5.00 per million BTU for gas 8,000 cfm supply and return airflows, continuous operation

| Plant Capacity Savings | UWC-64 | 64" - Competitive Option* |
|--------------------------|-----------|---------------------------|
| Total Effectiveness | 64.5% | 64.5% |
| Supply Air Pressure Loss | 0.51 inwg | 0.51 inwg |
| Return Air Pressure Loss | 0.51 inwg | 0.94 inwg |

Here is the difference in performance values between the two products based on AHRI listings

RER COMPARISON

| RER _{total} Comparison | UWC-68 | 64" - Competitive Option |
|---------------------------------|--------|--------------------------|
| Cooling RER _{total} | 121.4 | 67.9 |
| Heating RER _{total} | 206.1 | 115.2 |

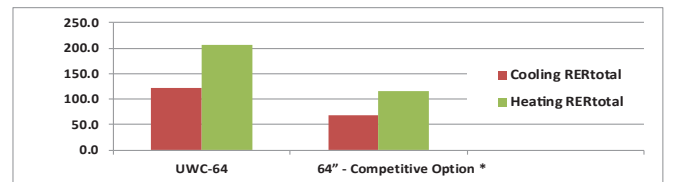

FLÄKTGROUP® SEMCO® CROSS CASSETTE 4

ENERGY SAVINGS COMPARISON

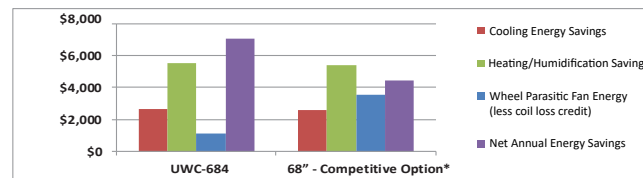

Comparison for SEMCO UWC-684 vs competitive 68" option using Atlanta weather conditions, \$10 for electricity and \$5.00 per million BTU for gas 8,000 cfm supply and return airflows, continuous operation

| Plant Capacity Savings | UWC-684 | ECW-664" - Competitive Option* |
|--------------------------|-----------|--------------------------------|
| Total Effectiveness | 64.6% | 63.0% |
| Supply Air Pressure Loss | 0.51 inwg | 1.25 inwg |
| Return Air Pressure Loss | 0.51 inwg | 1.25 inwg |

Here is the difference in performance values between the two products based on AHRI listings

RER COMPARISON

| RER _{total} Comparison | UWC-68 | 64" - Competitive Option |
|---------------------------------|--------|--------------------------|
| Cooling RER _{total} | 123.1 | 50.1 |
| Heating RER _{total} | 208.9 | 85.0 |

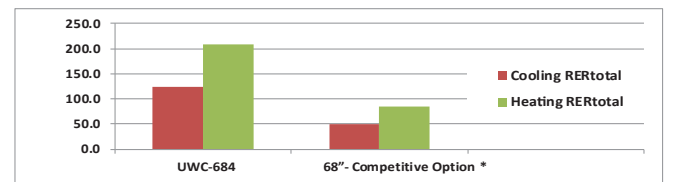

FLÄKTGROUP® SEMCO® FUSION CASSETTE

ENERGY SAVINGS COMPARISON

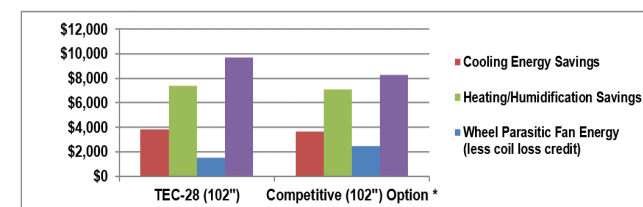

Comparison for SEMCO TEC-28 vs Competitive 102" wheel using Atlanta weather conditions, \$10 for electricity and \$5.00 per million BTU for gas 16,000 cfm supply and return airflows

| Plant Capacity Savings | TEC-28 (102") | 102" - Competitive Option* |
|--------------------------|---------------|----------------------------|
| Total Effectiveness | 75.0% | 71.5% |
| Supply Air Pressure Loss | 0.56 inwg | 0.80 inwg |
| Return Air Pressure Loss | 0.56 inwg | 0.80 inwg |

Here is the difference in performance values between the two products based on AHRI listings

RER COMPARISON

| RER _{total} Comparison | UWC-68 | 64" - Competitive Option |
|---------------------------------|--------|--------------------------|
| Cooling RER _{total} | 123.1 | 50.1 |
| Heating RER _{total} | 208.9 | 85.0 |

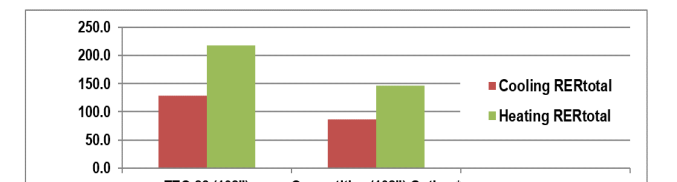

CLASSIC CASSETTE

PERFORMANCE DATA AND DIMENSIONS

CLASSIC CASSETTE DATA

| VELOCITY (SFPM) | EFFECTIVENESS | | | PRESSURE LOSS (INWG) |
|-----------------|---------------|--------|-------|----------------------|
| | SENSIBLE | LATENT | TOTAL | |
| 300 | 72 | 74 | 73 | 0.20 |
| 400 | 70 | 70 | 71 | 0.25 |
| 500 | 68 | 67 | 69 | 0.31 |
| 600 | 66 | 64 | 67 | 0.39 |
| 700 | 64 | 61 | 65 | 0.47 |
| 800 | 62 | 58 | 62 | 0.56 |
| 900 | 60 | 55 | 60 | 0.65 |

CLASSIC CASSETTE media employs a larger flute size, resulting in lower pressure loss and performance at the lowest product cost.

CLASSIC HIGH EFFICIENCY CASSETTE DATA

| VELOCITY (SFPM) | EFFECTIVENESS | | | PRESSURE LOSS (INWG) |
|-----------------|---------------|--------|-------|----------------------|
| | SENSIBLE | LATENT | TOTAL | |
| 300 | 76 | 76 | 76 | 0.29 |
| 400 | 73 | 74 | 73 | 0.36 |
| 500 | 71 | 72 | 72 | 0.46 |
| 600 | 69 | 69 | 69 | 0.57 |
| 700 | 67 | 67 | 67 | 0.69 |
| 800 | 65 | 64 | 64 | 0.82 |
| 900 | 63 | 61 | 62 | 0.94 |

CLASSIC HIGH EFFICIENCY CASSETTE media employs a smaller flute size, resulting in higher recovery performance at a slightly higher pressure loss and product cost.

| VELOCITY (SFPM) | DIMENSIONS (INCHES) | | | | | | | | | |
|-----------------|---------------------|--------|--------|--------|--------|--------|--------|--------|--------|--------|
| | UWC-36 | UWC-41 | UWC-46 | UWC-52 | UWC-58 | UWC-64 | UWC-68 | UWC-74 | UWC-78 | UWC-84 |
| 300 | 930 | 1,230 | 1,560 | 2,130 | 2,760 | 3,210 | 3,750 | 4,440 | 4,860 | 5,640 |
| 400 | 1,240 | 1,640 | 2,080 | 2,840 | 3,680 | 4,280 | 5,000 | 5,920 | 6,480 | 7,520 |
| 500 | 1,550 | 2,050 | 2,600 | 3,550 | 4,600 | 5,350 | 6,250 | 7,400 | 8,100 | 9,400 |
| 600 | 1,860 | 2,460 | 3,120 | 4,260 | 5,520 | 6,440 | 7,500 | 8,880 | 9,720 | 11,280 |
| 700 | 2,170 | 2,870 | 3,640 | 4,970 | 6,440 | 7,360 | 8,750 | 10,360 | 11,340 | 13,160 |
| 800 | 2,480 | 3,280 | 4,160 | 5,680 | 7,360 | 8,560 | 10,000 | 11,840 | 12,960 | 15,040 |
| 900 | 2,790 | 3,690 | 4,680 | 6,390 | 8,280 | 9,630 | 11,250 | 13,320 | 14,580 | 16,920 |

CLASSIC CASSETTE AND CLASSIC HIGH EFFICIENCY CASSETTE DIMENSIONS: 36 AND LARGER

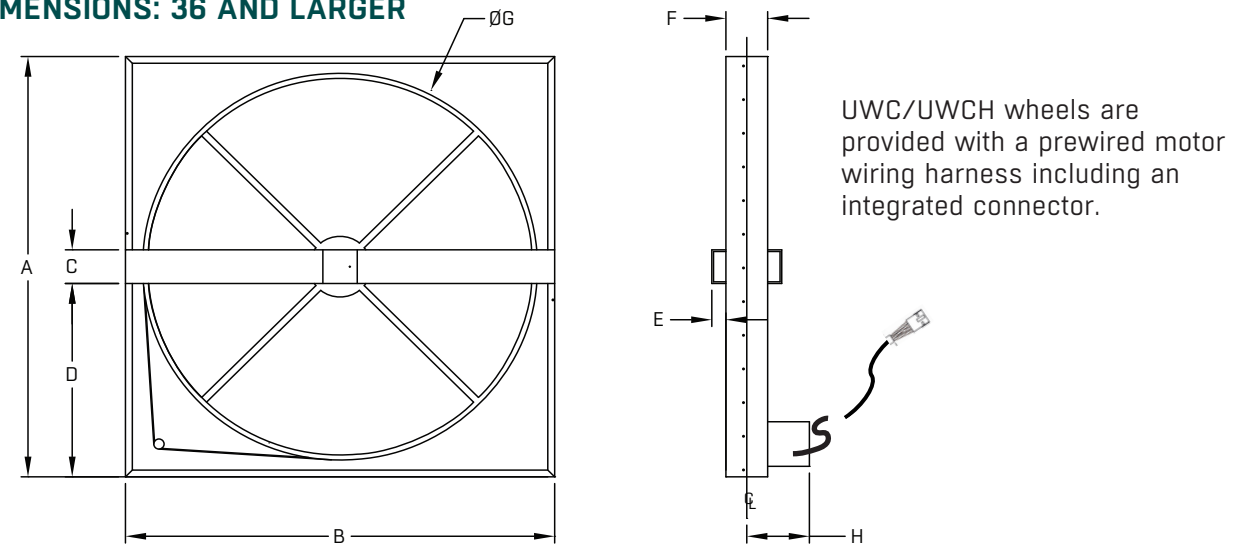

| MODEL # | DIMENSIONS (INCHES) | | | | | | | | | | UWC NET WEIGHT (LBS) | UWCH NET WEIGHT (LBS) | |
|---------|---------------------|-------|------|-------|------|------|----|------------|-----|-----|----------------------|-----------------------|-------------|
| | A | B | C | D | E | F | G | H (NOTE 1) | J | K | | | TOTAL WIDTH |
| UWC-36 | 39.80 | 39.80 | 2.82 | 18.40 | 1.31 | 4.36 | 36 | 5.5 (1) | N/A | N/A | 8.99 | 130 | 138 |
| UWC-41 | 44.00 | 44.00 | 3.10 | 20.50 | 1.58 | 4.36 | 41 | 5.5 (1) | N/A | N/A | 9.26 | 158 | 168 |
| UWC-46 | 50.00 | 50.00 | 3.10 | 23.50 | 1.58 | 4.36 | 46 | 5.5 (1) | N/A | N/A | 9.26 | 177 | 189 |
| UWC-52 | 56.19 | 56.19 | 3.10 | 26.50 | 1.58 | 4.36 | 52 | 5.5 (1) | N/A | N/A | 9.26 | 201 | 216 |
| UWC-58 | 62.42 | 62.42 | 3.10 | 29.70 | 2.05 | 4.36 | 58 | 7.5 | N/A | N/A | 14.04 | 238 | 257 |
| UWC-64 | 68.00 | 68.00 | 5.00 | 31.50 | 2.05 | 6.07 | 64 | 7.5 | N/A | N/A | 12.59 | 247 | 270 |
| UWC-68 | 72.00 | 72.00 | 6.00 | 33.00 | 2.05 | 7.07 | 68 | 7.5 | N/A | N/A | 13.09 | 262 | 288 |
| UWC-74 | 78.00 | 78.00 | 6.00 | 36.00 | 2.05 | 7.07 | 74 | 7.5 | N/A | N/A | 13.09 | 285 | 316 |
| UWC-78 | 85.00 | 85.00 | 6.00 | 39.5 | 2.14 | 7.07 | 78 | 10.5 | N/A | N/A | 16.18 | 617 | 652 |
| UWC-84 | 91.00 | 91.00 | 7.00 | 42.0 | 2.99 | 10.0 | 84 | 10.5 | N/A | N/A | 18.49 | 715 | 750 |

NOTE 1: Add 2" to "H Dimension" for the following applications: Constant Speed - 220V/1PH or 575V/3PH, Variable Speed - 460V/3PH or 575V/3PH

CLASSIC CASSETTE MOTORS

CLASSIC CASSETTE MOTOR MATRIX

POSITION

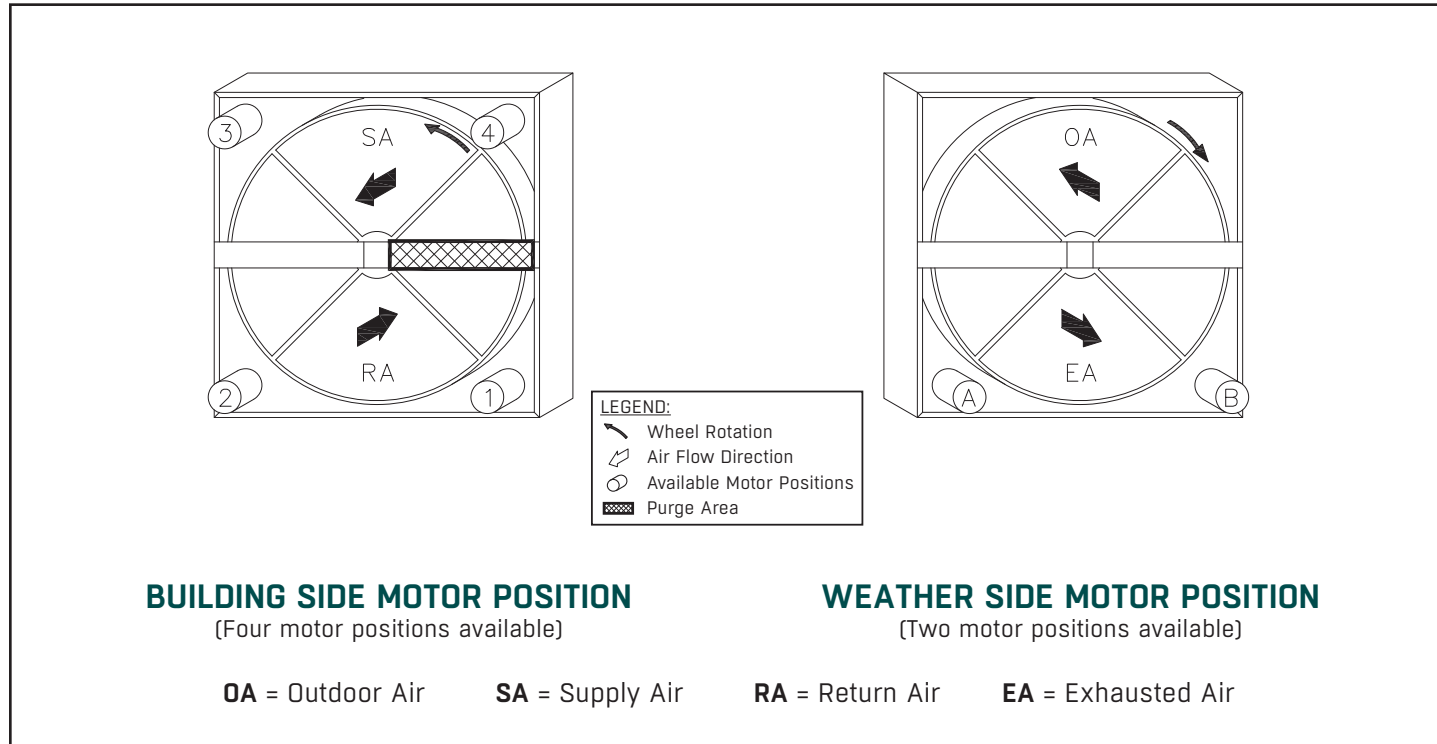

- The crosshatch section shown on the bearing support bar drawing is the location of the optional purge section
- The optional purge is always positioned on the building side of the wheel.
- Available motor positions are fixed as indicated on the drawings. For example, If the wheel is rotated 180° such that supply is on the bottom, motor position 1 is now located at the top left corner.
- Motor positions 1, 2, 3, and 4 are on the building side of the wheel. Motor position A and B are on the weather side of the wheel (opposite of 1 and 2 respectively)

CLASSIC CASSETTE AND CLASSIC HIGH EFFICIENCY CASSETTE CONFIGURATIONS AND MOTOR POSITIONS

The **CLASSIC AND CLASSIC HIGH EFFICIENCY CASSETTES** are offered to fit most configurations required by the OEM customer. The simple yet flexible design allows the OEM customer to rotate the wheel drawing on page into the appropriate orientation, then select the desired motor position from the options shown. To ensure proper performance, the **CLASSIC AND CLASSIC HIGH EFFICIENCY CASSETTES**, must be installed such that the wheel sections labeled as Supply Air and Outdoor Air are in the appropriate sections within the energy recovery unit – ERU – and the wheel rotation direction must be confirmed.

| CLASSIC CASSETTE MOTOR MATRIX | | CONSTANT SPEED OPERATION | | | | INVERTER DRIVEN VARIABLE SPEED OPERATION ⁽¹⁾ | | |
|-------------------------------|-----------------|--------------------------|-------------------|-------------------|------------------|---|------------------|-------------------------|
| MODEL # | MOTOR DETAILS | 220V/1PH | 208-230V/3PH | 460V/3PH | 575V/3PH | 208-230/3PH | 460V/3PH | 575V/3PH ⁽²⁾ |
| UWC-36 | Motor Model | GF18N005-BMYJ5C | GF15N005-BMRF2C | GF15N005-BMRF3C | G3K18N005-BMH8A | GF15N005-BMRF2C | G3K18N005-BMH4A | G3K18N005-BMH4A |
| | Horsepower Amps | 1/6 0.85 amps | 1/15 0.38 amps | 1/15 0.17 amps | 1/8 0.20 amps | 1/15 0.38 amps | 1/8 0.29 amps | 1/8 0.29 amps |
| UWC-41 | Motor Model | GF18N005-BMYJ5C | GF15N005-BMRF2C | GF15N005-BMRF3C | G3K18N005-BMH8A | GF15N005-BMRF2C | G3K18N005-BMH4A | G3K18N005-BMH4A |
| | Horsepower Amps | 1/6 0.85 amps | 1/15 0.38 amps | 1/15 0.17 amps | 1/8 0.20 amps | 1/15 0.38 amps | 1/8 0.29 amps | 1/8 0.29 amps |
| UWC-46 | Motor Model | GF18N005-BMYJ5C | GF15N005-BMRF2C | GF15N005-BMRF3C | G3K18N005-BMH8A | GF15N005-BMRF2C | G3K18N005-BMH4A | G3K18N005-BMH4A |
| | Horsepower Amps | 1/6 0.85 amps | 1/15 0.38 amps | 1/15 0.17 amps | 1/8 0.20 amps | 1/15 0.38 amps | 1/8 0.29 amps | 1/8 0.29 amps |
| UWC-52 | Motor Model | GF18N005-BMYJ5C | GF15N005-BMRF2C | GF15N005-BMRF3C | G3K18N005-BMH8A | GF15N005-BMRF2C | G3K18N005-BMH4A | G3K18N005-BMH4A |
| | Horsepower Amps | 1/6 0.85 amps | 1/15 0.38 amps | 1/15 0.17 amps | 1/8 0.20 amps | 1/15 0.38 amps | 1/8 0.29 amps | 1/8 0.29 amps |
| UWC-58 | Motor Model | N/A | GF18N005-BMYJ2C | GF18N005-BMYJ3C | G3K18N005-BMH8A | GF18N005-BMYJ2C | G3K18N005-BMH4A | G3K18N005-BMH4A |
| | Horsepower Amps | | 1/6 0.64 amps | 1/6 0.31 amps | 1/8 0.20 amps | 1/6 0.64 amps | 1/8 0.29 amps | 1/8 0.29 amps |
| UWC-64 | Motor Model | N/A | GF18N005-BMYJ2C | GF18N005-BMYJ3C | G3K18N005-BMH8A | GF18N005-BMYJ2C | G3K18N005-BMH4A | G3K18N005-BMH4A |
| | Horsepower Amps | | 1/6 0.64 amps | 1/6 0.31 amps | 1/8 0.20 amps | 1/6 0.64 amps | 1/8 0.29 amps | 1/8 0.29 amps |
| UWC-68 | Motor Model | N/A | GF18N005-BMYJ2C | GF18N005-BMYJ3C | G3K18N005-BMH8A | GF18N005-BMYJ2C | G3K18N005-BMH4A | G3K18N005-BMH4A |
| | Horsepower Amps | | 1/6 0.64 amps | 1/6 0.31 amps | 1/8 0.20 amps | 1/6 0.64 amps | 1/8 0.29 amps | 1/8 0.29 amps |
| UWC-74 | Motor Model | N/A | GF18N005-BMYJ2C | GF18N005-BMYJ3C | G3K18N005-BMH8A | GF18N005-BMYJ2C | G3K18N005-BMH4A | G3K18N005-BMH4A |
| | Horsepower Amps | | 1/6 0.64 amps | 1/6 0.31 amps | 1/8 0.20 amps | 1/6 0.64 amps | 1/8 0.29 amps | 1/8 0.29 amps |
| UWC-78 | Motor Model | N/A | G3K22N5-MF4AENTZ | G3K22N5-MF4AENTZ | N/A | G3K22N5-MF4AENTZ | G3K22N5-MF4AENTZ | N/A |
| | Horsepower Amps | | 1/2 1.8 amps | 1/2 0.9 amps | | 1/2 1.8 amps | 1/2 0.9 amps | |
| UWC-84 | Motor Model | N/A | G3K22N5-MF4AENTZ | G3K22N5-MF4AENTZ | N/A | G3K22N5-MF4AENTZ | G3K22N5-MF4AENTZ | N/A |
| | Horsepower Amps | | 1/2 1.8 amps | 1/2 0.9 amps | | 1/2 1.8 amps | 1/2 0.9 amps | |

NOTE 1: Proper motor class and inverter setup parameters are critical for proper variable speed motor operation. Preconfigured inverter from FläktGroup® SEMCO® recommended. For details please see page 20.

NOTE 2: Use 575V inverter. Program inverter for max 460 volts output.

NOTE 3: All wheels are equipped with 16" motor wiring lead with male Amp connector. The single phase, three wire, wire colors are black (3), green (2), and white (1). The three phase, four wire, wire colors are black (4), white (3), red (2), and green (1).

CROSS CASSETTE 4

PERFORMANCE DATA AND DIMENSIONS

PERFORMANCE DATA FOR CROSS CASSETTE 4

| VELOCITY FPM | EFFECTIVENESS % | PRESS. DROP IN.WG | AIR FLOW RATE (IN CFM) → | WHEEL SIZE | | | | |
|-----------------|-----------------|-------------------------|--------------------------|------------|---------|---------|---------|---------|
| | | | | UWC-364 | UWC-414 | UWC-464 | UWC-524 | UWC-584 |
| 300 | 73 | 0.20 | | 930 | 1,230 | 1,560 | 2,130 | 2,130 |
| 400 | 70 | 0.25 | | 1,240 | 1,640 | 2,080 | 2,840 | 3,680 |
| 500 | 68 | 0.31 | | 1,550 | 2,050 | 2,600 | 3,550 | 4,600 |
| 600 | 66 | 0.39 | | 1,860 | 2,460 | 3,120 | 4,260 | 5,520 |
| 700 | 63 | 0.47 | | 2,170 | 2,870 | 3,640 | 4,970 | 6,440 |
| 800 | 61 | 0.56 | | 2,480 | 3,280 | 4,160 | 5,680 | 7,360 |
| 900 | 59 | 0.65 | | 2,790 | 3,690 | 4,680 | 6,390 | 8,280 |

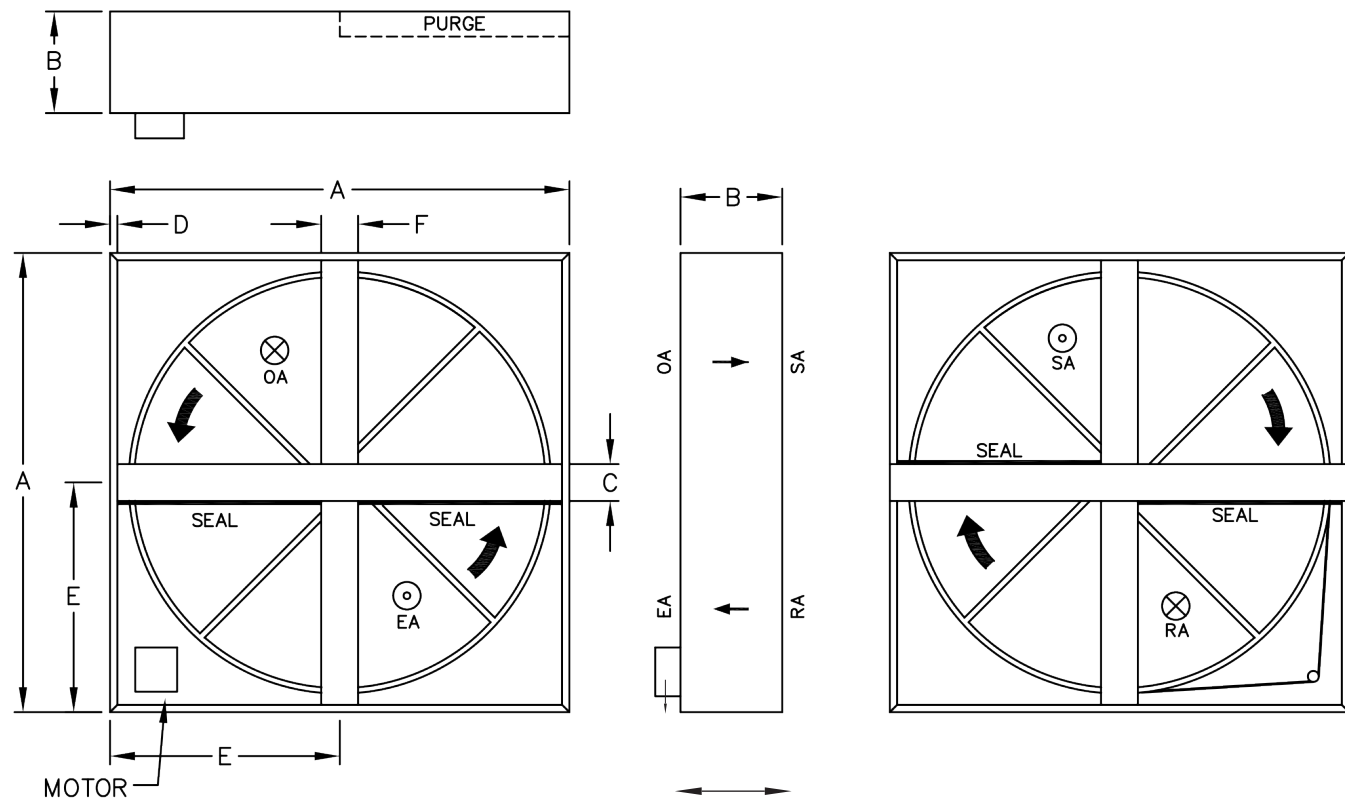

| MODEL # | WHEEL DEPTH | DIMENSIONS (INCHES) | | | | | | NET WT. (LBS.) | NOMINAL CFM |
|---------|-------------|---------------------|-------|-------|-------|--------|-------|----------------|-------------|
| | | A | B | C | D | E | F | | |
| UWC-364 | 3.75" | 44.00" | 7.00" | 2.50" | 1.00" | 22.00" | 2.60" | 138 | 2300 |
| UWC-414 | 3.75" | 48.00" | 7.00" | 2.50" | 1.00" | 24.00" | 2.60" | 176 | 3000 |
| UWC-464 | 3.75" | 54.00" | 8.00" | 2.75" | 2.00" | 27.00" | 2.90" | 224 | 3900 |
| UWC-524 | 3.75" | 60.00" | 8.00" | 2.75" | 2.00" | 30.00" | 2.90" | 282 | 5000 |
| UWC-584 | 3.75" | 66.00" | 8.00" | 2.75" | 2.00" | 33.00" | 2.90" | 347 | 6200 |

PERFORMANCE DATA FOR CROSS CASSETTE 4

| VELOCITY FPM | EFFECTIVENESS % | PRESS. DROP IN.WG | AIR FLOW RATE (IN CFM) → | WHEEL SIZE | | | |
|-----------------|-----------------|----------------------|--------------------------|------------|---------|---------|---------|
| | | | | UWC-684 | UWC-744 | UWC-784 | UWC-844 |
| 300 | 73 | 0.20 | | 3,750 | 4,440 | 4,860 | 5,640 |
| 400 | 70 | 0.25 | | 5,000 | 5,920 | 6,480 | 7,520 |
| 500 | 68 | 0.31 | | 6,250 | 7,400 | 8,100 | 9,400 |
| 600 | 66 | 0.39 | | 7,500 | 8,880 | 9,720 | 11,280 |
| 700 | 63 | 0.47 | | 8,750 | 10,360 | 11,340 | 13,160 |
| 800 | 61 | 0.56 | | 10,000 | 11,840 | 12,960 | 15,040 |
| 900 | 59 | 0.65 | | 11,250 | 13,320 | 14,580 | 16,920 |

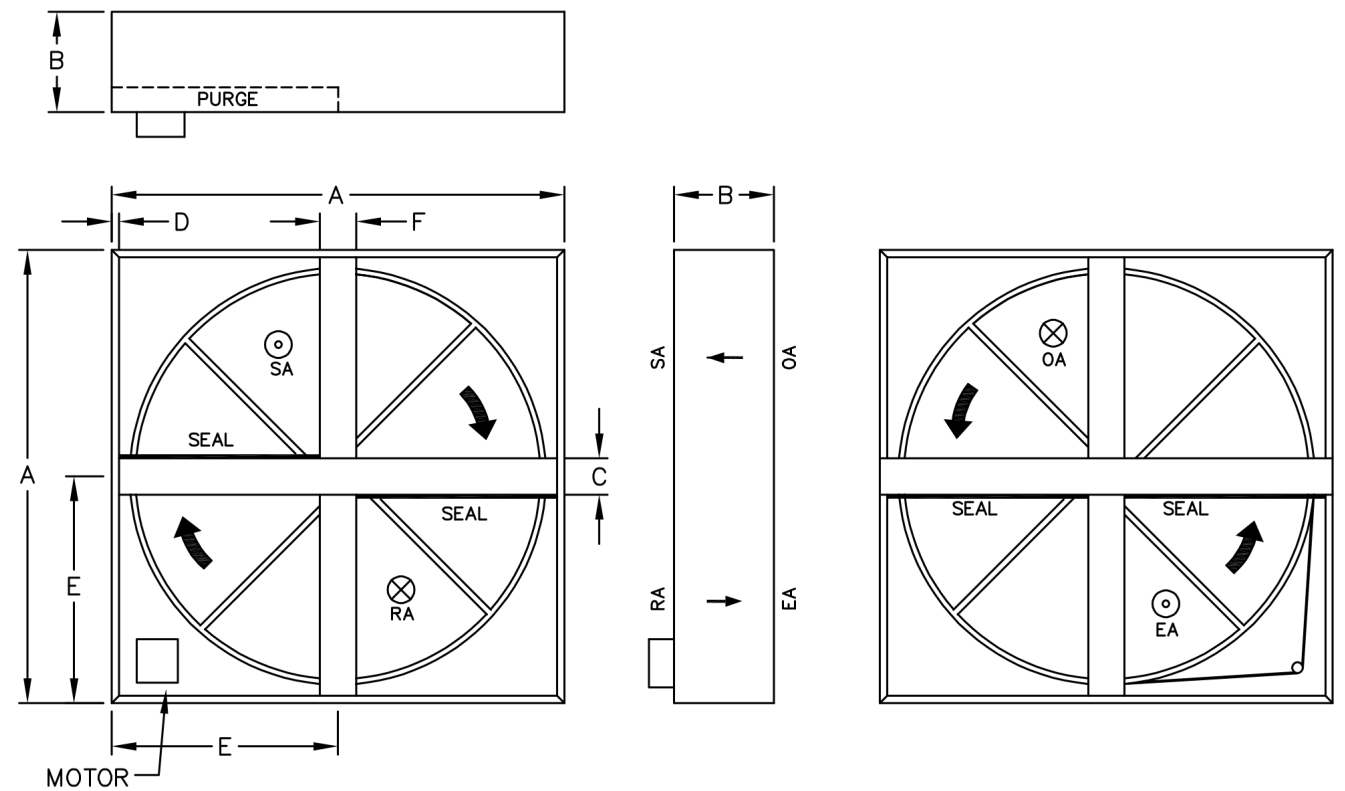

| MODEL # | WHEEL DEPTH | DIMENSIONS (INCHES) | | | | | | NET WT. (LBS.) | NOMINAL CFM |
|---------|-------------|---------------------|-------|-------|-------|--------|-------|----------------|-------------|
| | | A | B | C | D | E | G | | |
| UWC-684 | 3.75" | 72.00" | 9.00" | 4.00" | 1.50" | 36.00" | 4.20" | 472 | 8600 |
| UWC-744 | 3.75" | 78.00" | 9.00" | 4.00" | 1.50" | 39.00" | 4.20" | 555 | 10200 |
| UWC-784 | 3.75" | 84.00" | 9.50" | 5.00" | 2.00" | 42.00" | 4.50" | 620 | 11300 |
| UWC-844 | 3.75" | 90.00" | 9.50" | 5.00" | 2.00" | 45.00" | 4.50" | 715 | 13200 |

CROSS CASSETTE 4 MOTOR MATRIX

| CROSS CASSETTE 4 MOTOR MATRIX | | CONSTANT SPEED OPERATION | | | | INVERTER DRIVEN VARIABLE SPEED OPERATION ⁽¹⁾ | | |
|----------------------------------|-----------------------------------|--|--|--|---|--|---|---|
| MODEL # | MOTOR DETAILS | 220V/1PH | 208-230V/3PH | 460V/3PH | 575V/3PH | 208-230/3PH | 460V/3PH | 575V/3PH ⁽²⁾ |
| UWC-364 | Motor Model Horsepower Amps | GF18N005- BMRE5C 1/20 0.31 amps | GF15N005- BMRF2C 1/15 0.38 amps | GF15N005- BMRF3C 1/15 0.17 amps | GF18N005- BMH8A 1/8 0.20 amps | GF15N005- BMRF2C 1/15 0.38 amps | G3K18N5- MF1AENXTZ 1/8 0.29 amps | G3K18N005- BMH8A 1/8 0.20 amps |
| UWC-414 | Motor Model Horsepower Amps | GF18N005- BMYJ5C 1/6 0.85 amps | GF15N005- BMRF2C 1/15 0.38 amps | GF15N005- BMRF3C 1/15 0.17 amps | GF18N005- BMH8A 1/8 0.20 amps | GF15N005- BMRF2C 1/15 0.38 amps | G3K18N5- MF1AENXTZ 1/8 0.29 amps | G3K18N005- BMH8A 1/8 0.20 amps |
| UWC-464 | Motor Model Horsepower Amps | GF18N005- BMYJ5C 1/6 0.85 amps | GF15N005- BMRF2C 1/15 0.38 amps | GF15N005- BMRF3C 1/15 0.17 amps | GF18N005- BMH8A 1/8 0.20 amps | GF15N005- BMRF2C 1/15 0.38 amps | G3K18N5- MF1AENXTZ 1/8 0.29 amps | G3K18N005- BMH8A 1/8 0.20 amps |
| UWC-524 | Motor Model Horsepower Amps | GF18N005- BMYJ5C 1/6 0.85 amps | GF15N005- BMRF2C 1/15 0.38 amps | GF15N005- BMRF3C 1/15 0.17 amps | GF18N005- BMH8A 1/8 0.20 amps | GF15N005- BMRF2C 1/15 0.38 amps | G3K18N5- MF1AENXTZ 1/8 0.29 amps | G3K18N005- BMH8A 1/8 0.20 amps |
| UWC-584 | Motor Model Horsepower Amps | N/A | GF18N005- BMYJ2C 1/6 0.64 amps | GF18N005- BMYJ3C 1/6 0.31 amps | G3K18N005- BMH8A 1/8 0.20 amps | GF18N005- BMYJ2C 1/6 0.64 amps | G3K18N5- MF1AENXTZ 1/8 0.29 amps | G3K18N005- BMH8A 1/8 0.20 amps |
| UWC-684 | Motor Model Horsepower Amps | N/A | GF18N005- BMYJ2C 1/6 0.64 amps | GF18N005- BMYJ3C 1/6 0.31 amps | GF18N005- BMH8A 1/8 0.20 amps | GF18N005- BMYJ2C 1/6 0.64 amps | G3K18N5- MF1AENXTZ 1/8 0.29 amps | G3K18N005- BMH8A 1/8 0.20 amps |
| UWC-744 | Motor Model Horsepower Amps | N/A | GF18N005- BMYJ2C 1/6 0.64 amps | GF18N005- BMYJ3C 1/6 0.31 amps | GF18N005- BMH8A 1/8 0.20 amps | GF18N005- BMYJ2C 1/6 0.64 amps | G3K18N5- MF1AENXTZ 1/8 0.29 amps | G3K18N005- BMH8A 1/8 0.20 amps |
| UWC-784 | Motor Model Horsepower Amps | N/A | G3K18N5- MF2AENTZ 1/4 1.0 amps | G3K18N5- MF2AENTZ 1/4 0.5 amps | N/A | G3K18N5- MF2AENTZ 1/4 1.0 amps | G3K18N5- MF2AENTZ 1/4 0.5 amps | N/A |
| UWC-844 | Motor Model Horsepower Amps | N/A | G3K18N5- MF2AENTZ 1/4 1.0 amps | G3K18N5- MF2AENTZ 1/4 0.5 amps | N/A | G3K18N5- MF2AENTZ 1/4 1.0 amps | G3K18N5- MF2AENTZ 1/4 0.5 amps | N/A |

NOTE 1: Proper motor class and inverter setup parameters are critical for proper variable speed motor operation. Preconfigured inverter from FläktGroup SEMCO recommended. For details please see page 20.

NOTE 2: Use 575V inverter. Program inverter for max 460 volts output.

NOTE 3: All wheels are equipped with 16" motor wiring lead with male Amp connector. The single phase, three wire, wire colors are black (3), green (2), and white (1). The three phase, four wire, wire colors are black (4), white (3), red (2), and green (1).

CROSS CASSETTE 6 MOTOR MATRIX

| CROSS CASSETTE 6 MOTOR MATRIX | | CONSTANT SPEED OPERATION | | | INVERTER DRIVEN VARIABLE SPEED OPERATION ⁽¹⁾ | |
|----------------------------------|-----------------------------------|---|---|---|--|---|
| MODEL # | MOTOR DETAILS | 220V/1PH | 208-230V/3PH | 460V/3PH | 208-230/3PH | 460V/3PH |
| UWC-466 | Motor Model Horsepower Amps | GF18N005- BMYJ5C 1/6 0.85 amps | GF18N005- BMYJ2C 1/6 0.64 amps | GF18N005- BMY3C 1/6 0.31 amps | GF15N005- BMRF2C 1/15 0.38 amps | G3K18N005- BMH8A 1/8 0.20 amps |
| UWC-526 | Motor Model Horsepower Amps | GF18N005- BMYJ5C 1/6 0.85 amps | GF18N005- BMYJ2C 1/6 0.64 amps | GF18N005- BMY3C 1/6 0.31 amps | GF15N005- BMRF2C 1/15 0.38 amps | G3K18N005- BMH8A 1/8 0.20 amps |
| UWC-586 | Motor Model Horsepower Amps | N/A | GF18N005- BMYJ2C 1/6 0.64 amps | GF18N005- BMY3C 1/6 0.31 amps | GF18N005- BMYJ2C 1/6 0.64 amps | G3K18N005- BMH8A 1/8 0.20 amps |
| UWC-686 | Motor Model Horsepower Amps | N/A | G3K18N5- MF2AENTZ 1/4 1.0 amp | GK18N5- MF2AENTZ 1/4 0.5 amps | G3K18N5- MF2AENTZ 1/4 1 amp | G3K18N5- MF2AENTZ 1/4 0.5 amps |
| UWC-746 | Motor Model Horsepower Amps | N/A | G3K18N5- MF2AENTZ 1/4 1 amp | G3K18N5- MF2AENTZ 1/4 0.5 amps | GF18N5- MF2AENTZ 1/4 1.0 amp | G3K18N5- MF2AENTZ 1/4 0.5 amps |
| UWC-786 | Motor Model Horsepower Amps | N/A | G3K18N5- MF2AENTZ 1/4 1.0 amp | G3K18N5- MF2AENTZ 1/4 0.5 amps | G3K18N5- MF2AENTZ 1/4 1.0 amps | G3K18N5- MF2AENTZ 1/4 0.5 amps |
| UWC-846 | Motor Model Horsepower Amps | N/A | G3K18N5- MF2AENTZ 1/4 1.0 amp | G3K18N5- MF2AENTZ 1/4 0.5 amps | G3K18N5- MF2AENTZ 1/4 1.0 amp | G3K18N5- MF2AENTZ 1/4 0.5 amps |
| UWC-906 | Motor Model Horsepower Amps | N/A | G3K18N5- MF2AENTZ 1/4 1.0 amp | G3K18N5- MF2AENTZ 1/4 0.5 amps | G3K18N5- MF2AENTZ 1/4 1.0 amp | G3K18N5- MF2AENTZ 1/4 0.5 amps |
| UWC-966 | Motor Model Horsepower Amps | N/A | G3K18N5- MF2AENTZ 1/4 1.0 amp | G3K18N5- MF2AENTZ 1/4 0.5 amps | G3K18N5- MF2AENTZ 1/4 1.0 amp | G3K18N5- MF2AENTZ 1/4 0.5 amps |
| UWC-1026 | Motor Model Horsepower Amps | N/A | G3K18N5- MF2AENTZ 1/4 1.0 amp | G3K18N5- MF2AENTZ 1/4 0.5 amps | G3K18N5- MF2AENTZ 1/4 1.0 amp | G3K18N5- MF2AENTZ 1/4 0.5 amps |
| UWC-1086 | Motor Model Horsepower Amps | N/A | G3K18N5- MF2AENTZ 1/4 1.0 amp | G3K18N5- MF2AENTZ 1/4 0.5 amps | G3K18N5- MF2AENTZ 1/4 1.0 amp | G3K18N5- MF2AENTZ 1/4 0.5 amps |

NOTE 1: Proper motor class and inverter setup parameters are critical for proper variable speed motor operation. Preconfigured inverter from SEMCO recommended. For details please see page 20.

NOTE 2: Use 575V inverter. Program inverter for max 460 volts output.

NOTE 3: All wheels are equipped with 16" motor wiring lead with male Amp connector. The single phase, three wire, wire colors are black (3), green (2), and white (1). The three phase, four wire, wire colors are black (4), white (3), red (2), and green (1).

CROSS CASSETTE 6

PERFORMANCE DATA AND DIMENSIONS

PERFORMANCE DATA FOR THE CROSS CASSETTE 6

| VELOCITY FPM | EFFECTIVENESS % | PRESS. DROP IN.WG | Air Flow Rate (in CFM) | MODEL NUMBER | | | | | | | | | | |
|-----------------|--------------------|-------------------------|------------------------|--------------|---------|---------|---------|---------|---------|---------|---------|---------|----------|----------|
| | | | | UWC-466 | UWC-526 | UWC-586 | UWC-686 | UWC-746 | UWC-786 | UWC-846 | UWC-906 | UWC-966 | UWC-1026 | UWC-1086 |
| 400 | 76 | 0.36 | | 2,160 | 2,800 | 3,480 | 4,840 | 5,720 | 6,400 | 7,440 | 8,560 | 9,760 | 11,040 | 14,120 |
| 500 | 73 | 0.47 | | 2,700 | 3,500 | 4,350 | 6,050 | 7,150 | 8,000 | 9,300 | 10,700 | 12,200 | 13,800 | 17,640 |
| 600 | 71 | 0.58 | | 3,240 | 4,200 | 5,220 | 7,260 | 8,580 | 9,600 | 11,160 | 12,850 | 14,650 | 16,550 | 21,180 |
| 700 | 68 | 0.71 | | 3,780 | 4,900 | 6,090 | 8,470 | 10,010 | 11,200 | 13,020 | 14,980 | 17,080 | 19,320 | 24,720 |
| 800 | 66 | 0.84 | | 4,320 | 5,600 | 6,960 | 9,680 | 11,440 | 12,800 | 14,880 | 17,080 | 19,530 | 22,090 | 28,250 |
| 900 | 63 | 0.97 | | 4,860 | 6,300 | 7,830 | 10,890 | 12,870 | 14,400 | 16,740 | 19,320 | 21,950 | 24,840 | 31,800 |

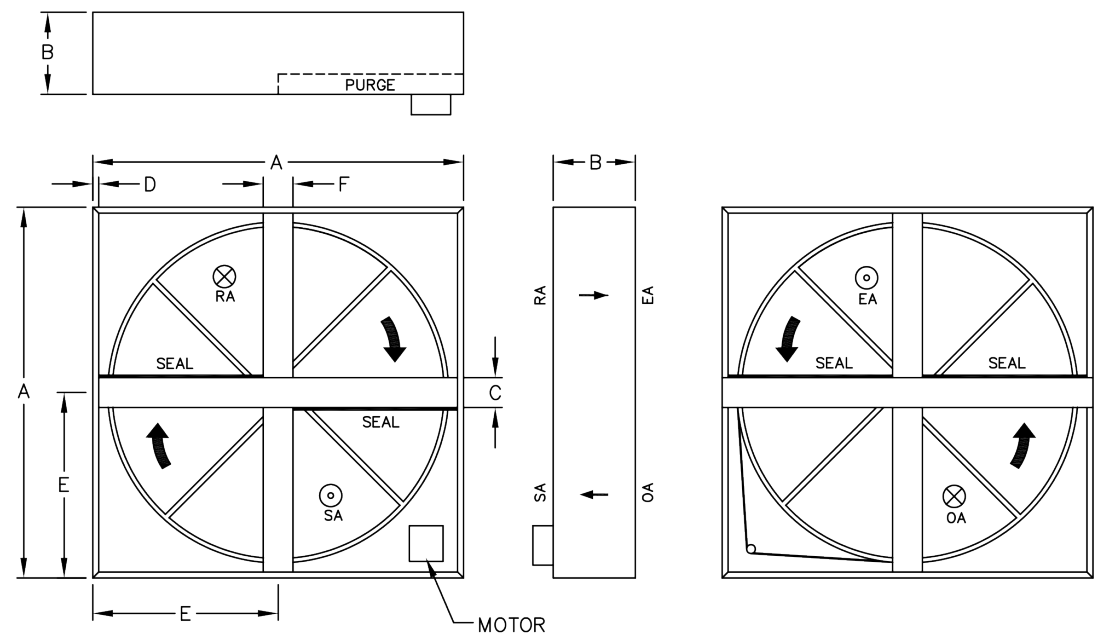

| MODEL # | WHEEL DEPTH | DIMENSIONS (INCHES) | | | | | | NET WT. (LBS.) | NOMINAL CFM |
|----------|----------------|---------------------|--------|-------|-------|--------|-------|----------------|-------------|
| | | A | B | C | D | E | F | | |
| UWC-686 | 6.00" | 72" | 11.00" | 4.00" | 1.50" | 36.00" | 4.20" | 431 | 8,500 |
| UWC-746 | 6.00" | 78" | 11.00" | 4.00" | 1.50" | 39.00" | 4.20" | 508 | 10,000 |
| UWC-786 | 6.00" | 84" | 12.00" | 5.00" | 2.00" | 42.00" | 4.60" | 566 | 11,200 |
| UWC-846 | 6.00" | 90" | 12.00" | 5.00" | 2.00" | 45.00" | 4.60" | 655 | 13,000 |
| UWC-906 | 6.00" | 96" | 12.00" | 6.00" | 2.00" | 48.00" | 4.60" | 750 | 15,000 |
| UWC-966 | 6.00" | 102" | 12.00" | 6.00" | 2.00" | 51.00" | 4.60" | 852 | 17,100 |
| UWC-1026 | 6.00" | 108" | 12.00" | 6.00" | 2.00" | 54.00" | 4.60" | 962 | 19,300 |

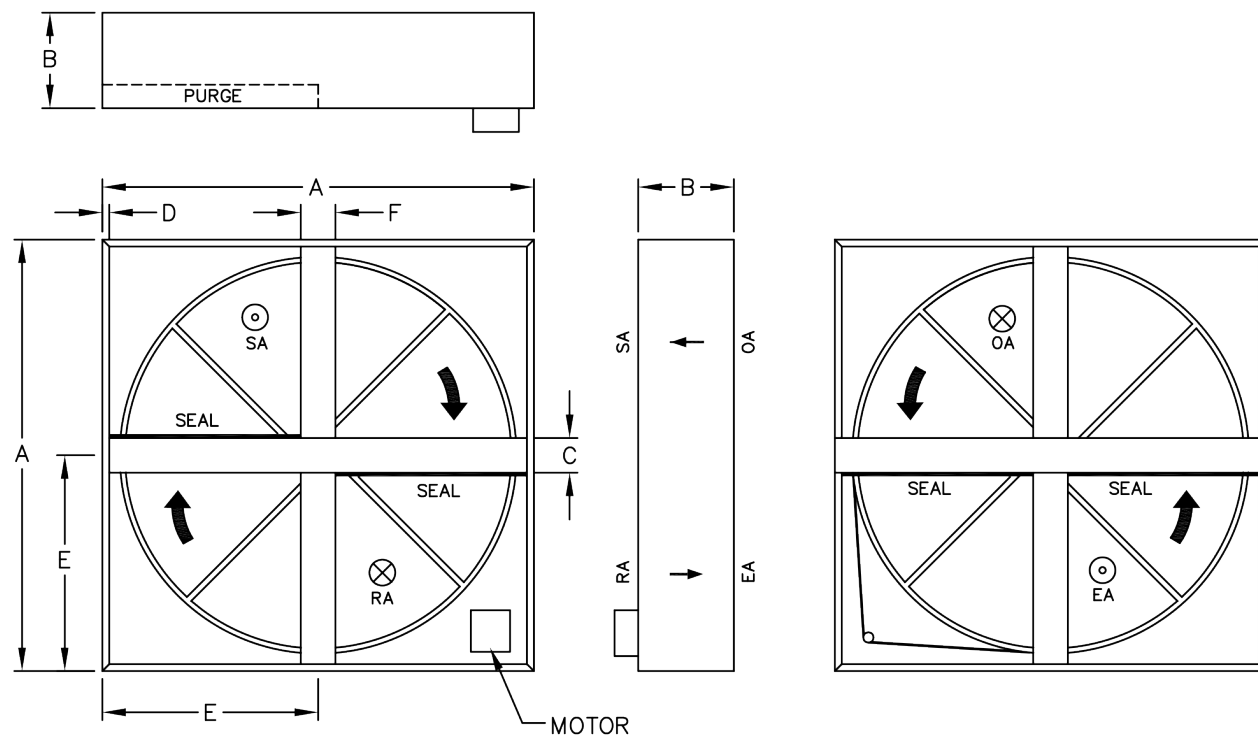

| MODEL # | WHEEL DEPTH | DIMENSIONS (INCHES) | | | | | | NET WT. (LBS.) | NOMINAL CFM |
|---------|----------------|---------------------|--------|-------|-------|--------|-------|-------------------|-------------|
| | | A | B | C | D | E | F | | |
| UWC-466 | 6.00" | 54.00" | 10.00" | 2.75" | 2.00" | 27.00" | 2.90" | 203 | 3,800 |
| UWC-526 | 6.00" | 60.00" | 10.00" | 2.75" | 2.00" | 30.00" | 2.90" | 256 | 4,900 |
| UWC-586 | 6.00" | 66.00" | 10.00" | 2.75" | 2.00" | 33.00" | 2.90" | 316 | 6,100 |

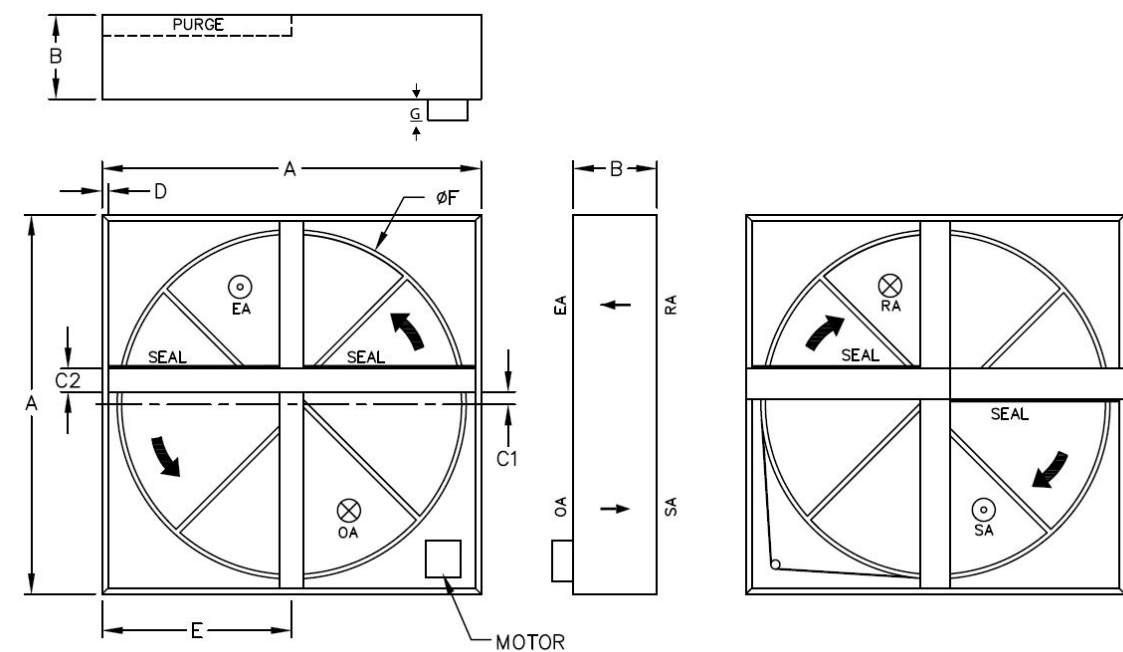

| MODEL # | WHEEL DEPTH | DIMENSIONS (INCHES) | | | | | | | NET WT. (LBS.) | NOMINAL CFM |
|----------|----------------|---------------------|--------|-------|-------|-------|--------|-------|-------------------|----------------|
| | | A | B | C1 | C2 | D | E | F | | |
| UWC-1086 | 6.00" | 116.25" | 14.63" | 6.87" | 2.75" | 2.00" | 58.13" | 4.60" | 1078 | 24,700 |



Whether you already have a FläktGroup® SEMCO® air handling unit, and need a replacement, or have one of our competitor's units, and want to upgrade your UWC to the best in the industry, we have a wheel that meets your needs. Check the reference chart below, to find the perfect wheel for your air handling unit.

TOTAL ENERGY RECOVERY WHEEL

The rotor media must be made of aluminum which is formed into a fluted, honeycomb matrix which and coated to prohibit corrosion; paper, fibrous or plastic medias are not acceptable. All surfaces must be coated with a non-migrating zeolite desiccant composite designed to maximize latent recovery while reducing the transfer of airborne contaminants, which are often times abundant in silica gel or oxidized aluminum recovery wheels. The wheel media shall be a permanent component with an estimated 20 year life and not a "throw away" item. The component should be suitable for integration within units incorporating heating sources of all types without damage and designed to accommodate operating conditions up to 180°F.

The recovery wheel product performance must be AHRI certified. Submitted data must be based upon this certified data, meeting or exceeding the temperature and latent efficiencies scheduled. The wheel pressure loss data must not exceed that scheduled for the supply and return air streams. The product performance must also meet or exceed the design heating and cooling RER (recovery efficiency ratio) values listed within the schedule.

The recovery media must have been independently tested by a recognized laboratory to show compliance with UL-900 requirements with regard to smoke generation and combustibility. A full copy of the UL-900 test report must be provided for review with submittals.

The recovery wheel media can be cleaned with low temperature steam, hot water or light detergent without degrading the latent recovery.

PURGE SECTOR

The unit must be available with a purge sector designed to limit cross-contamination of the exhaust air stream concentration when operated under appropriate design conditions.

ROTOR SEALS

The rotor shall be supplied with pre-adjusted low leakage hybrid brush seals to separate the two air streams

ROTOR SUPPORT SYSTEM

The rotor media must be re-enforced with an aluminum structural spoke system, extruded central hub and shaft sized to limit deflection and to ensure long-term structural integrity.

UNIT HOUSING

The rotor housing must be designed to limit deflection of the rotor due to air pressure loss. The sheet metal panels shall be made of galvanized steel to prevent corrosion. The rotor shall be supported by internal sealed bearings that are permanently lubricated to reduce maintenance requirements.

DRIVE SYSTEM

The drive system, must be driven by a reinforced, industrial grade adjustable link belt system. Plastic stretch belts are not acceptable. An A/C gear motor specifically designed for high torque, low speed operation is utilized for constant and variable speed applications.

The 460 volt motors supplied for inverter duty have been specifically designed for achieving long life in inverter driven applications, are NEMA MG1 Section IV Part 31 compliant and have UL/CSA/CE/RoHS certifications.

SOLE AND EXCLUSIVE WARRANTY

Please see the terms and conditions for your order or contact service.semco@flaktgroup.com.



SEMCO CONVERSION CHART

| Classic Cassette Series | AirXChange® | Cross Cassette 4 Series | NovelAire® 4" | Cross Cassette 6 Series | NovelAire® 6" |
|-------------------------|-------------|-------------------------|---------------|-------------------------|---------------|
| UWC-36 | ERC-36 | UWC-364 | ECW-364 | UWC-526 | ECW-546 |
| UWC-41 | ERC-41 | UWC-414 | ECW-424 | UWC-586 | ECW-606 |
| UWC-46 | ERC-46 | UWC-464 | ECW-484 | UWC-686 | ECW-666 |
| UWC-52 | ERC-52 | UWC-524 | ECW-544 | UWC-746 | ECW-726 |
| UWC-58 | ERC-58 | UWC-584 | ECW-604 | UWC-786 | ECW-786 |
| UWC-64 | ERC-64 | UWC-684 | ECW-664 | UWC-846 | ECW-846 |
| UWC-68 | ERC-68 | UWC-744 | ECW-784 | UWC-906 | ECW-906 |
| UWC-74 | ERC-74 | UWC-784 | ECW-784 | UWC-966 | ECW-966 |
| UWC-78 | ERC-81 | UWC-844 | UWC-844 | UWC-1026 | ECW-1026 |
| UWC-84 | ERC-86 | — | — | UWC-1086 | ECW-1086 |

EXCELLENCE IN SOLUTIONS

WWW.SEMCOHVAC.COM / UWV/UWCH WHEEL / 20240103

FläktGroup® SEMCO® delivers smart, energy-efficient, air-quality solutions to support every building application. We offer our customers innovative technologies, high-quality products and outstanding performance supported by more than fifty years of accumulated industry experience. The broadest offering on the market and a strong market presence in 65 countries worldwide guarantees that we are always by your side, ready to deliver.

FläktGroup® SEMCO®

Corporate Headquarters
1800 East Pointe Drive
Columbia, Missouri 65201 USA

573.443.1481

sales.semco@flaktgroup.com

To learn more about FläktGroup® SEMCO® offerings and to contact your nearest representative please visit

www.semcohvac.com



© Copyright 2024 SEMCO LLC. All Rights Reserved. SEMCO embraces a policy of continuous development and improvement, the right is reserved to supply products which may differ from those illustrated and described in this publication. Specifications are subject to change without further notice. Any FläktGroup SEMCO purchase is subject to FläktGroup SEMCO standard terms and conditions. Certified dimensions will be supplied upon request on receipt of order. SEMCO is a registered Trademark of SEMCO LLC. Other trademarks and logos in this publication may be property of SEMCO, LLC, its subsidiaries or any of its related companies and/or other organizations or individuals. U.S. patented technology. AirXChange® is a registered trademark of Airxchange Inc. NovelAire® is a registered trademark of NovelAire Technologies, AADN® is a registered trademark of Aaon® GREENHECK® is a registered trademark of Greenheck Fan Corp®, Carrier Corporation® is a registered trademark of UTC Climate Controls and Security® a Unit of United Technologies Corp® CLIMATEMASTER® is a registered trademark of ClimateMaster Inc.®, LENNOX® is a registered trademark of Lennox International! Inc.®, McQuay International® is a registered trademark of McQuay Air-Conditioning, LTD.®, DAIKIN® is a registered trademark of Daikin Industries, LTD®,

Trane® is a registered trademark of Trane International Inc.